

Cattle yards



design,
materials and
construction

THIRD EDITION

Cattle yards

design,
materials and
construction

THIRD EDITION

Evan Powell and John Lapworth

ISSN 0727-6273
ISBN 0 7242 2259 6
Agdex 420/722

First published 1986
Reprinted 1992 with amendments
Reprinted 1994
Reprinted 1996
Second edition 1998
Reprinted 2002
Third edition 2006

General disclaimer

Information contained in the publication is provided as general advice only. For application to specific circumstances, professional advice should be sought.

The Department of Primary Industries and Fisheries, Queensland has taken all reasonable steps to ensure that the information contained in this publication is accurate at the time of production. Readers should ensure that they make appropriate inquiries to determine whether new information is available on the particular subject matter.

© The State of Queensland, Department of Primary Industries and Fisheries 2006

Copyright protects this publication. Except for purposes permitted by the Copyright Act, reproduction by whatever means is prohibited without prior written permission of the Department of Primary Industries and Fisheries, Queensland.

Inquiries should be addressed to:
Manager, DPI&F publications
Department of Primary Industries and Fisheries
GPO Box 46
Brisbane Qld 4001

Contents

About the authors	iv
Introduction	1
Workers safety in yards	2
Animal behaviour and welfare	4
Yard operations	5
Yard location	6
Yard protection	7
Materials and construction	8
Cattle behaviour and planning hints	11
Gates and gateways	14
Yards within yards	20
Drafting	22
Forcing pens	27
Races	29
Race gates	33
Veterinary crushes	36
Head bails	39
Loading ramps	41
calf races	44
Plunge dips	46
Cattle scales	49
Artificial breeding facilities	51
Portable yards	52
Yard plans	53
Glossar	64
Further reading	66

About the authors

The late Evan Powell was a beef adviser with the Department of Primary Industries and Fisheries, Queensland.

John Lapworth is a Principal Project Officer with the Department of Primary Industries and Fisheries, Queensland. John has extensive experience in transport handling and welfare of livestock and is currently based in Brisbane.

Introduction

Cattle yards are an essential facility for raising beef cattle. Once built they last for many years; as a result few cattlemen erect more than one or two yards in a lifetime. A poorly designed set of yards can lead to years of inconvenience and frustration, while well-planned yards save on manpower, enable efficient handling of stock, minimise bruising and are a pleasure to work in.

There are many yard designs, none of which is perfect for all operations. However, those in which cattle work well have certain features in common and many of these features are discussed in this book.

Before building a new set of yards, study as many plans as possible, observe a number of yards in operation, and then combine these experiences with your requirements and start planning.

New yards are expensive so take care to ensure minimal maintenance and future operating costs by selecting the best plan and materials for your enterprise.

The basic facilities for close handling of various sizes of herds are similar. It is possible to construct a nucleus that can be added to as cattle numbers and operations demand. The main difference between a yard designed for 200 head of cattle and a yard for 2000 head is the size of the receiving and holding yards. Excessive capital expenditure on sturdy yard fences can be reduced by having several small holding paddocks which enable the stock to be worked in smaller groups. Most yards require facilities for receiving, holding and moving cattle into smaller working yards for drafting, animal restraint, loading and unloading. Calf branding facilities are required for breeding herds, whereas a dip may be necessary in cattle tick infested country.

The design of the yard and the capital invested will depend on the number of cattle to be handled now and in the foreseeable future, the number of people available to work in the yards, the operations to be conducted and the frequency of yard use. Design the yards to suit a one-person operation where possible, and so that all yards are stock-proof for all classes of cattle.

This book has been written to suit on-farm situations rather than large commercial feedlots, even though cattle handling principles remain the same.

Worker safety in yards

There are several reasons why workplace health and safety in cattle yard designs should be considered:

- the safety of workers, family and visitors
- legislative requirements
- defence in common law litigation
- work efficiency

Many injuries result from kicks and gate accidents because of the unpredictable nature of cattle, poor stockmanship or poorly designed and maintained facilities.

Yard design alone will not prevent worker injury. Following good stockmanship principles, and using appropriate equipment and clothing, will also assist in reducing risk.

Animal stress is a major cause of worker injury, as well as having a negative impact on carcase quality. Some design and construction features may reduce the chance of worker injury:

- use material of sufficient strength and durability
- position gates to reduce chance of workers getting stuck
- have strong positive self-latching gates
- provide easy operator escape avenues from yards such as manways, foot holes and open rail construction
- use strong and durable rail attachments
- allow sufficient space to avoid overcrowding cattle
- avoid noisy equipment, materials and constructions
- plan yards so that animals can see a clear path in the required direction
- where horses are used, ensure that cap rails are well above the rider's height
- avoid sharp or protruding objects in the yards
- avoid using slippery material in walk areas
- consider possible injury from veterinary crush levers and gates
- in high throughput yards, consider plans that enable stock to be worked from outside forcing areas
- design pound drafting gate poles to reduce the chance of operators being speared
- plan to minimise dust
- have a walkway beside loading ramps
- ensure that power lines are well clear of double-deck cattle trailers where handlers work on the top
- redesign features that cause shadows and reduce the free flow of animals.

For further information on workplace health and safety issues in Queensland, refer to the most recent edition of the *Workplace Health and Safety Act 1995* and *Workplace Health and Safety Regulation 1997* and *Workplace Health and Safety (Miscellaneous) Regulations 1995*.

For any other enquiries, contact the Division of Workplace Health and Safety, Department of Training and Industrial Relations.

Or visit the Farm Safe website pages relating to cattle yards at:

- www.farmsafe.org.au/images/pdfs/Beef_Practical_Guide.pdf “Safe Cattle Handling”
- www.farmsafe.com.au/fsafe_sms_entry.html

Animal behaviour and welfare

Animal welfare is an important issue for cattle producers as they are responsible for the animals in their care. They must provide the basic needs of water, food, shelter and safety for their animals. In the yard situation these needs can be supplied in many ways and actually improve the efficiency of beef production.

Many welfare problems that arise in cattle yards are easily overcome by taking into account normal animal behaviour. Where these factors are considered in yard design and construction, the time spent handling and processing cattle in yards will be significantly reduced and animals will be more content.

Where possible, avoid handling cattle in the heat of the day. Animals work better in cooler conditions. Overcrowding should also be avoided as it causes confusion, significantly increases handling time and predisposes cattle to injury. Cattle need social contact and should not be left on their own.

Some important welfare/behaviour features include the use of cooling yards, curved races, sheeting, visual barriers, regular maintenance, the removal of protrusions and noise reduction. The supply of adequate water and feed trough space is essential.

All head bails should use a walk-through design. Other designs can cause choking and other injuries.

Cooling yards are particularly important on larger properties as they allow animals to settle for a period and recover from the stresses of mustering or handling in the yards. During this cooling period calves are able to 'mother up', and calf losses are virtually eliminated. After the cooling or settling periods animals can then be more easily handled in yards, moved back to pasture and loaded onto transport.

In areas where water is available, watering the yards improves the conditions for working cattle and reduces the danger to stockmen.

It has often been said, 'Look after your animals and they will look after you'. This really means that good handling equates to good animal welfare.

National Codes of Practice for the welfare of animals are generally available from State Departments of Primary Industries or Agriculture. These codes give the recommended minimum standards required for animal welfare.

Yard operations

In the table below, operations for which the yards are required are noted in order of necessity and priority. Facilities to cater for these operations are given opposite them. Where practical, these facilities should be combined and included in the new yard plan.

Operations	Facilities
Drafting	Drafting yard, pound, drafting race, or a combination of these
Loading and unloading	Ramp and race
Cattle-tick treatment	A water supply with a dip or spray race or, with very small numbers, a hand-spraying race, pour-ons in race
Tick movement inspection	Race with access to both sides of animals
Disease testing	Race
Cross branding	Race or veterinary crush
Worming	Race or head bail
Ear tagging	Race
Dehorning	Head bail for adults, calf cradle for calves
Horn tipping	Head bail
Weighing	Scales
Eye treatment	Head bail
Lice treatment	Small yard or race
Pregnancy testing	Race or veterinary crush
Artificial insemination	Veterinary crush
Calf branding	Cradle, flank-bar
Castrating calves	As for branding
Vaccinations	Veterinary crush, race, cradle for calves
Earmarking calves	Cradle
Weaning and calf education	Yard with water, shade and feed trough or hay rack
Veterinary treatment	Veterinary crush with head bail or race
Calving assistance	Race
Spraying	Veterinary crush
Hoof trimming	Veterinary crush
Resting (cooling)	Large yard or small paddock with shade and water
Ear implants	Head bail

Yard location

Ideally, yards should be centrally located, with the holding paddock having direct access to as many paddocks as possible. Where this is not possible, a laneway system greatly increases handling efficiency. Extensive holdings may require more than one set of yards.

Alternatively, a large permanent handling facility sited around or near a water point may be further supported by strategically placed smaller yards or portable yards.

All-weather vehicle access is best. Where all-weather access is available at the property boundary but not to the central yards, a lockable loading facility may be located near the boundary.

Preferably, build yards on a 1 to 2% slope that provides drainage from the working area and the yard site. Gullies, hollows and obstructions such as rocky areas that impede stock movement and prevent expansion should be avoided.

The site should be open but not devoid of trees. Shade is desirable in holding paddocks and cooling yards. Close-working yards, which are often boggy, should remain exposed to the sun or be cemented. Isolated trees are a nuisance in working yards; they are better located outside the yard or in a fenced-off corner. A roof over the main working area is more comfortable for the operator although this is only practical where race floors are concreted. Few trees will survive in regularly used yards.

The yard aspect should be such that prevailing winds do not blow dust from the close-working yards to the race area or towards nearby living quarters. Suitably located tree lines can reduce wind and dust problems.

A site with loam or gravel soil is preferable to one with heavy clay soils, as the loam and gravel soils are less boggy and generally less dusty. Soil movement and boggy conditions are problems with heavy clay soils.

Reduce mud problems by providing drainage, concreting the race, gravelling the pound and forcing yards, and removing shade from boggy areas.

A water supply is required for stock water, filling and topping up dipping vats, laying dust, and for hygiene during veterinary procedures.

Reduce the risk of stock theft by having all vehicle access to yards passing within view of the house.

Dipping vats located near houses should be made child-proof.

Because of problems relating to residue contamination of meat products, sites known to have a previous history of contamination with chemicals should be avoided.

Yard protection

Termites (white ants) can damage timber yards. Most termite problems are avoided by using metal posts or preventing timber structures from coming in contact with the ground. Where steel posts are not practical, use desapped durable timbers or treated timber posts and protect them with a chemically treated soil barrier. Posts should be treated to H5 level, and branded, in accordance with the requirements of the *Timber Utilisation and Marketing Act (TUMA) 1987*, at a commercial treatment plant.

Reduce deterioration of timber structures by bevelling post tops, using desapped durable timbers (durability class 1 and some class 2) and also by chemical treatment. Most hardwood timber species can be treated with a commercial preservative. Treating timber increases the durability of the sapwood equal to that of the heartwood, enabling thinner posts and rails to be used.

Posts can be protected with a chemically treated soil barrier. The recommended chemicals for soil treatment should be used according to label directions.

Installing chemical soil barriers does not negate the need for regular inspection. Do not allow loose timber to be left against rails and do not allow untreated soil to cover the treated barrier, as these can act as a bridge over the barrier.

In acid soils, steel yards should be epoxy-coated to about 300 mm above ground level. A cement collar above ground line should also be added to reduce corrosion from soil build-up around the posts.

Painting of steel work in cattle yards is important. It is also a significant additional yard construction cost and needs to be considered from a maintenance point of view.

Carefully dispose of chemical residues from treatments. All equipment used to handle these chemicals should be thoroughly flushed with water, then rinsed with detergent. Mix the detergent with water at the rate of 50 mL/100 L. Put the washing fluid in a safe area. Avoid treating soil areas that are likely to be exposed by erosion. Use in accordance with the safety directions on the label.

A well-maintained firebreak protects timber constructions.

Further information can be obtained as follows:

on timber durability and use, and on termites: Timber Queensland
500 Brunswick Street
PO Box 2014
Fortitude Valley Q 4006
Ph: 07 3254 1989 Fax: 07 3254 1964
email: admin@timberqueensland.com.au
website: timberqueensland.com.au

on TUMA: Department of Primary Industries and Fisheries
Forestry Research Building
80 Meiers Rd
Indooroopilly Q 4068
Ph: 13 25 23
email: callweb@dpi.qld.gov.au

Materials and construction

Many different materials are used for yard construction; this chapter discusses their availability, durability, purchase price, erection cost and suitability. The construction of the yard should be such that it will last many years and do the job required as efficiently as possible for the least initial cost. The amount invested in constructing a yard should be gauged by the number of cattle and the frequency of use.

Cattle generally work well in solid constructions presenting a blank barrier in all directions except where they are required to move. Unfortunately, such fences are usually the most expensive. Materials used should help to reduce animal stress by providing visual barriers. This will also reduce bruising and improve worker safety.

Round and sawn timber, timber offcuts, bore casing, pipe and railway line are suitable for posts. Round timber posts for corners and gateways should be 300 to 350 mm minimum diameter and set 1000 mm in the ground (you may need to use steel in bad ant areas but be careful of steel in acid soils). Panel posts should be 250 mm minimum diameter and set 900 mm in the ground. Round posts for cooling yards should be 200 mm minimum diameter and set 750 mm in the ground. Round timber posts are usually cheaper than sawn timber posts. (Dimensions given are free of sapwood unless preserved.)

In areas where termites (white ants) are bad, steel posts may have to be used. Where steel posts are erected in acid soils it may be necessary to coat the inground section with a 2-pack paint. Painting should extend about 300 mm above ground level. A cement collar should also be domed around the post to reduce the chance of soil build-up corroding any unprotected steel.

Timber rails are suitable for all yard fences. Erection costs considered, there is often little difference in the total cost of sawn, round or split rails, as fitting round and split rails

takes more time. Timber rails are best fastened by wire twitches (Figure 1) or countersunk bolts.

Holes should not be bored in the ends of badly splitting timbers; instead, wrap the wire around the rail. Nails and spikes should not be used unless in conjunction with a wire twitch. Rails of double panel length make

Figure 1
Cobb & Co. wire twitch

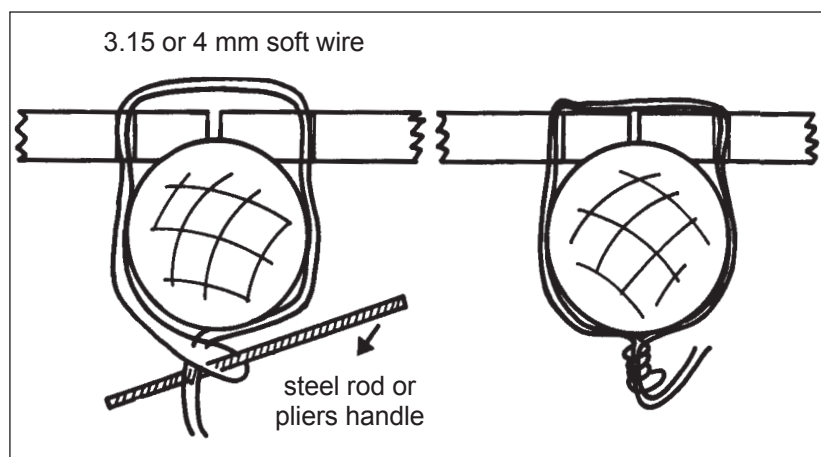

a stronger construction. Rail ends should abut on alternate posts for alternate rails.

Rails are attached to the cattle-working side of posts, presenting a smooth line for cattle to follow.

Top rail height, in close-working yards, should be from 1.7 m for quiet cattle to 2 m for infrequently handled fractious cattle. Fence height in receiving and cooling yards should also be 1.7 to 2 m. Round rails should not be less than 140 mm in diameter. Sawn timber rails should not be smaller than 130 x 50 mm; preferably 130 x 65 mm or 150 x 65 mm.

Rail spacings should be close enough to restrain small calves and prevent adult cattle attempting to get through. Suggested maximum spacings between rails are:

- ground to bottom rail 300 mm
- 250 mm for the next two spacings
- 250 to 280 mm above that.

Figure 2 illustrates a four-rail fence with recommended maximum rail spacings.

Panel length varies according to the material used and stock pressure on the panel. Suggested panel lengths are:

- race 2 to 2.4 m
- close-working yards 2.4 to 2.6 m
- holding yards 2.6 to 3 m.

Steel mesh is suitable for receiving and holding yards but should not be used in close-working yards. Mesh construction makes yards calf-proof so it can be used in conjunction with a cap rail in receiving and holding areas. Mesh should not be used in a race as stock tend to catch their legs or be injured by broken wire strands, and operators find it difficult and dangerous to work cattle through these meshed areas.

Steel cable (8 mm minimum diameter strand) is suitable for larger, low-pressure yards where a visual barrier is not so important. Combining cable with a cap rail enable cables to be correctly tensioned. The cap rail also provides a visual barrier to reduce jumping. Used cable is often available from mines, fishing trawler operators, and lift (elevator) or crane companies. Cable is less expensive than timber or pipe construction.

Maximum cable spacings between strands from the ground upwards are 300 mm, 180 mm, 180 mm, 180 mm, 230 mm and 250 mm for subsequent strands. Wider spacings are suitable if only adult cattle are to be handled.

Tension is achieved with tightening bolts or turnbuckles on

Figure 2 Four-rail fence

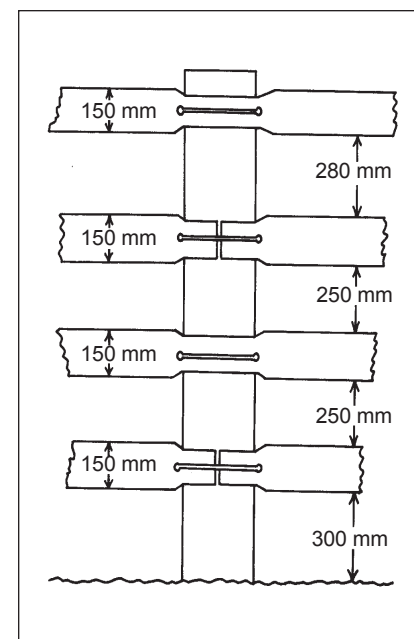

each strand. To prevent turnbuckles from working loose, lock nuts should be used and tightened. By using a system of pulleys on posts, a single length of cable can run back and forth as strands of different heights with only one tightening device controlling the tension.

Pipe is satisfactory in close-working yards. It is strong and durable and provides an excellent race surface for the operator to work over. Pipe or other steel panels on pipe posts can be noisy. This noise can be reduced by filling the posts with concrete. Fifty mm internal diameter pipe is considered the minimum.

Figure 3
Pipe rail maximum spacings

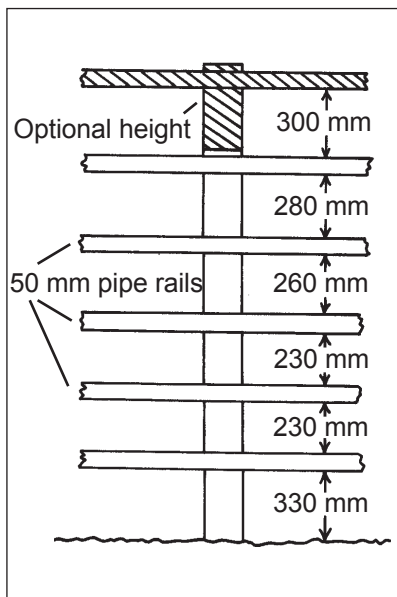

Suggested maximum spacings for a 50 mm pipe rail fence are shown in Figure 3.

Steel sheeted panels are robust and the blanking effect is good in many situations; unfortunately, steel may be too expensive. For safety reasons foot holes or manways are required to assist the operator to make a fast exit.

Other materials suitable for stockyard panelling include timber off-cuts, heavy-duty plywood and heavy-duty conveyor belting. Heavy railway line makes good posts and strong rails and is suitable where open vision is satisfactory. When using railway line it should be preheated before welding and low hydrogen rods need to be used when welding.

Other steel material that can also be used in yard construction are a rounded hollow section rail commonly called 'cattle rail', or flat section rails commonly referred to as 'W' rails. These materials have rounded edges to reduce injuries and bruising. They also provide a good visual barrier.

Water troughs should be located away from gateways, corners or forcing areas in holding or cooling yards. Water troughs should not be placed in smaller yards.

Complete a detailed paper plan before starting construction. Check that the external measurements fit within the selected area and peg out the complete yard plan. Start construction with the dipping vat, then build the race back towards the pound. If no dip is involved, erect the pound first. Gate posts are the next to be positioned. Where possible, make gates to fit the opening. However, prefabricated gates are often more convenient so take care to ensure a good fit when standing posts. It is best to start construction from the centre and work outwards. In this way any measurement errors can be corrected as you go, and will not affect overall yard construction.

The shape of the yard affects its construction cost. A circle requires the least fencing to enclose a given area. Semicircles and triangles have a poor internal area-to-perimeter ratio.

Cattle behaviour & planning hints

Consider the following points when planning yards and handling cattle:

- the side of the race you prefer to work (most right-handers usually prefer the near side, that is, the left side)
- the side on which calves are branded (a mirror image of most plans will change these first two aspects)
- ease of application of electronic eartags requires free access to off-side of head bail
- cattle follow a curve more readily than a straight line
- cattle work better on a slight uphill slope
- avoid substantial downhill slopes

- turns less than 90° reduce cattle flow and increase bruising
- have a fence that provides a visual barrier for cattle if they have to be worked past cattle in an adjoining yard (Figure 4)

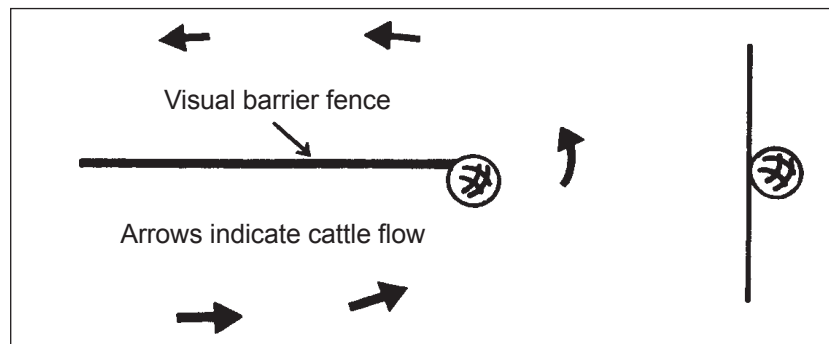

Figure 4 Visual barrier fence

- cattle become bewildered and more nervous if they cannot see or are not allowed the time to see where they are required to go
- cattle often will not flow through a gateway if the path is back past the entrance gate (Figure 5). Stock will return to the entrance gate by themselves but often hesitate to move further, especially if the direction in which the handler wishes them to go is away from the direction in which they entered the yards. If this is unavoidable, a wing should be constructed to assist movement past the entrance point. The wing should not interfere with the vision of cattle moving into the yard (Figure 6)
- visual barrier fences usually result in better cattle flow and fewer attempts to break out, provided the fences do not block the view of where the cattle are required to go
- cattle are more likely to flow into a deep yard (draw in). Cattle baulk at entering a shallow solid yard if they cannot see a way through. A 'see-through' but strong fence at the far side of the receiving yard encourages cattle to enter (Figure 7)
- gate approaches should be 90° or less (Figure 8).

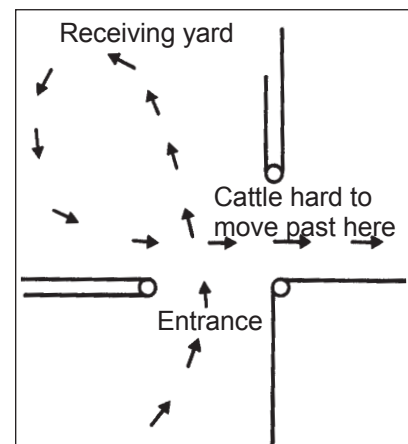

Figure 5 Entrance gate location

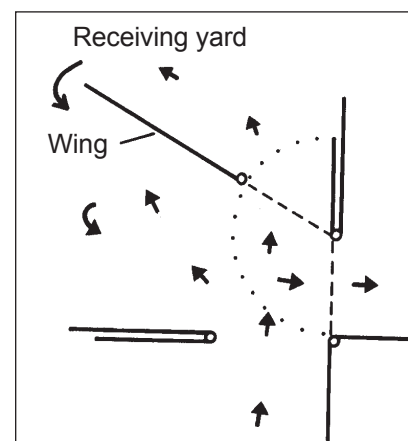

Figure 6 Forcing wing

If regularly worked cattle enter and leave the yard complex by different gates they are encouraged to work towards the exit. Handling difficulties can be experienced if using the same gate for entrance and exit.

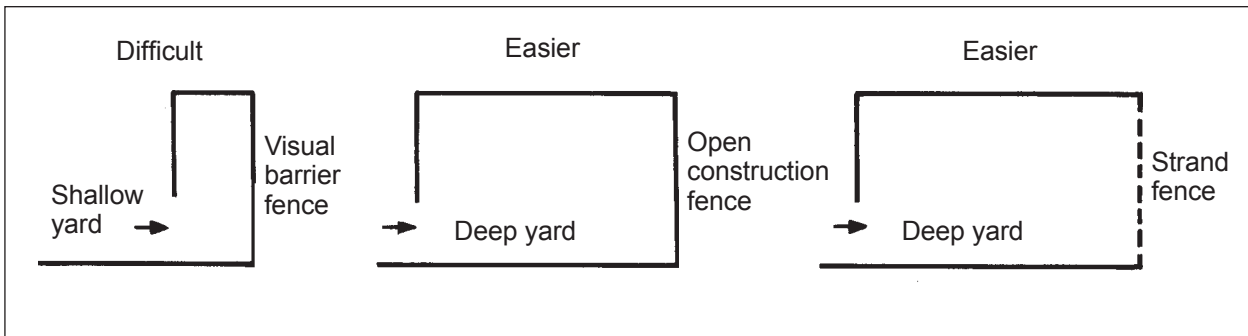

Figure 7 Cattle prefer to move into a deep yard

Yards wider than 6 m often require more than one person to move cattle.

The distance operators have to walk should be minimised.

Weaners should be educated to the way you want them to work through the yards.

There are many advantages in having hornless cattle, such as improved safety for the operator and other animals, and the fact that more hornless cattle can be fitted into the same space. Hornless cattle generally have significantly less bruising.

Cattle react to noise; keep it to a minimum. Do not shout, but talk quietly to stock.

Keep stress and work time to a minimum through patient, careful and quiet handling.

Dogs are often more trouble than they are worth in the yards, especially with cows and calves. They also tend to encourage cattle to kick. Dogs should not be used in yards.

Cull highly excitable cattle as they usually excite the rest of the cattle, making them more difficult to handle and increasing the incidence of bruising. They are also a threat to personal safety.

A flapper is ideal in assisting cattle movement. Reserve electric prods for occasional use in the veterinary crush and loading areas.

Figure 8 Gate approaches

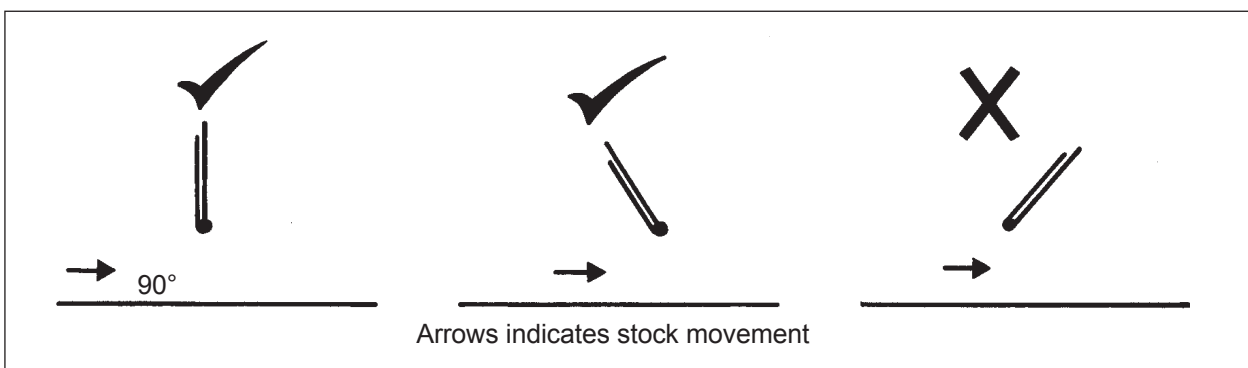

If a beast reaches the over-excited stage of lying down, leave it alone. Continued prodding increases stress and severe shock, and may result in death.

Leaving a sole animal in a small yard will cause it to become stressed and agitated and often results in injury to the animal.

Cattle move towards light. Forcing them into dark or heavily shaded areas is difficult. If working at night, diffused light is best as extreme contrasting shadows will hinder cattle flow. Night loading can be improved by lighting the inside of the truck crate.

When moving a mob and one breaks back, letting a few animals back to join the escapee makes it easier to return that animal to the mob.

Cattle have 360° panoramic vision with poor depth perception and a smaller visual field (25 to 50°) in front in which they have depth perception. Where possible work at 45 to 60° behind the shoulder of the animal you wish to move, that is, the lead animal (Figure 9).

Cattle tend to follow one another so it is best to concentrate on moving the leaders.

Cattle are worked more easily in a group.

It is easier to work with small groups of cattle. Draft off the number that can be easily handled and move them to the next work area. Moving the whole mob and then letting some back only encourages breaking and creates yard rogues.

Do not overcrowd yards, especially in forcing areas.

Set a routine and stick to it.

*Figure 9
Stockman's working position*

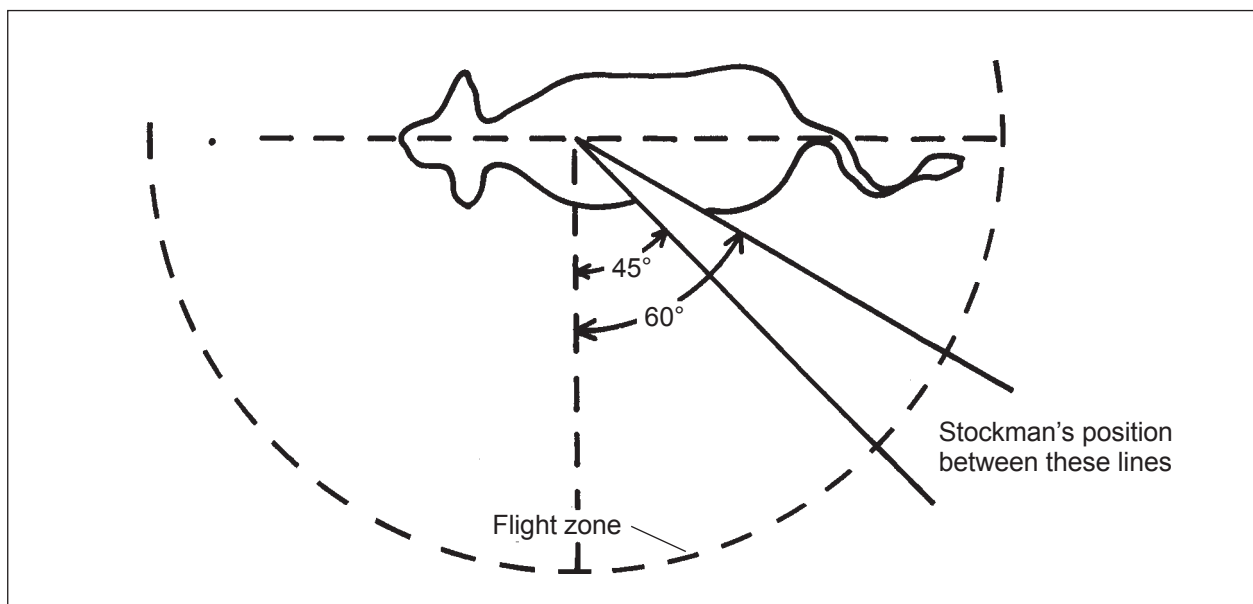

Gates and gateways

All gateways should be located along or near fence lines as shown in Figures 10A, B and C. Gateway location as illustrated in Figure 10B should only be used where mobs larger than 500 head are being yarded.

Varying widths of gateway are required for most cattle yards. The receiving gateway should have a minimum width of 3 m for less than 100 head and up to 5 m for larger mobs. Double

wooden gates are usually required for openings over 3 m, but a well-constructed pipe gate may span more than 4 m. Forcing yard gates are usually 2.5 to 3 m, pound exit gates 1.5 to 2.2 m, race gates 1.8 to 2.1 m and other gates 2.5 m wide. Vehicle access should be considered when planning gates.

Gates are usually constructed to swing 300 mm from the

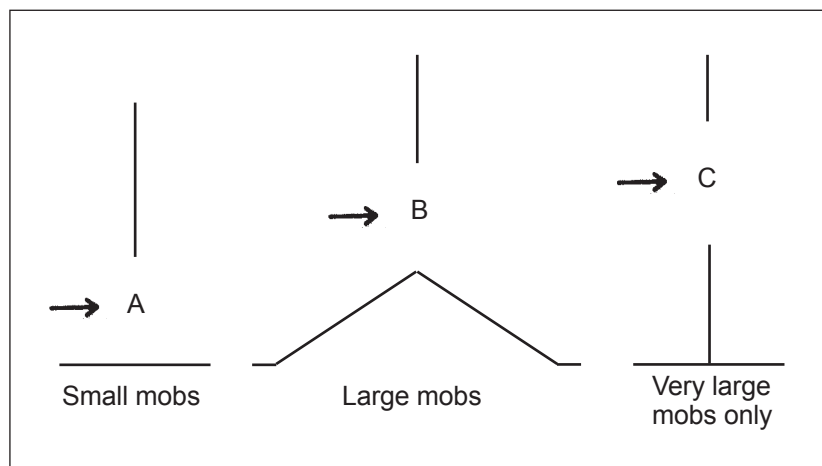

Figure 10 Gateway location

ground and be the same height as abutting fences.

Gate construction should present a visual barrier to stock. Traditional sawn timber gates are expensive to construct and heavy to swing, requiring well-stayed gate posts, but they do present a good barrier.

Timber gates (Figure 11a) should be constructed of boards 25 to 30 mm thick by 125 to 150 mm wide. Use cup head bolts with flat washers under the nut. After tightening, cut the bolt off flush with the end of the nut. Wooden stays go from the bottom on the hinge side to the top on the latch side; a double stay stops the gate from twisting. The distance

between boards should not exceed 230 mm.

Figure 11a Timber gate

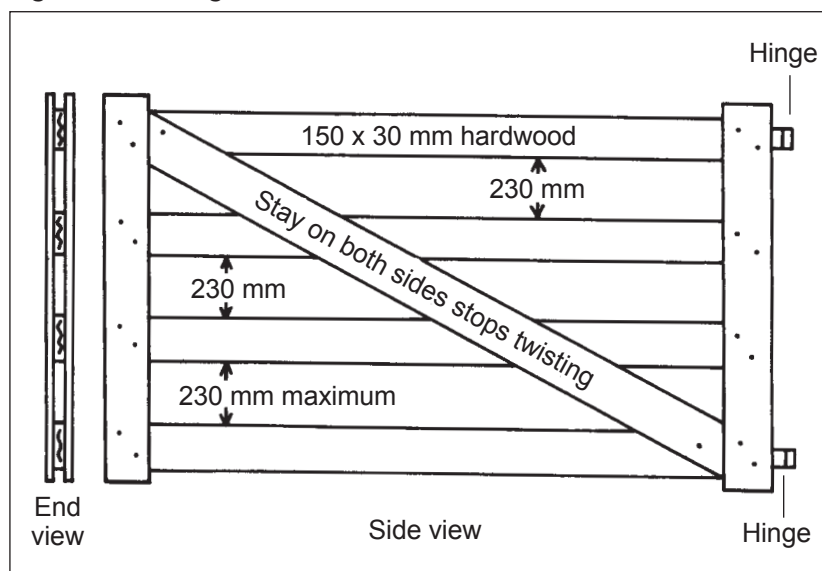

Black and galvanised pipe (Figure 11b) makes strong lightweight gates that are easy to swing. However, some cattle will attempt to escape through such gates unless they are blanked-in to present a total visual barrier. Pipes should be no more than 230 mm apart in open construction gates. Use at least 38 mm diameter pipe for the external frame

and 32mm for internal bars. Steel mesh gates are not recommended but where used must be modified to present a suitable visual barrier.

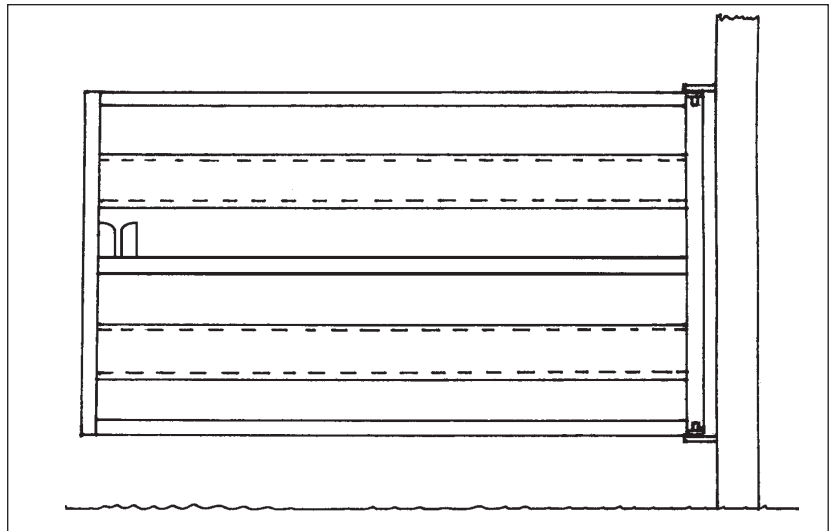

Figure 11b Pipe gate

Gatepost staying

Gateposts need greater support than normal panel posts. They are set 1 m (minimum) in the ground and may need to be concreted in. Posts for heavy gates with wide openings require greater staying than those for light gates over small openings.

A cap rail (Figure 12) is the strongest means of staying a gateway. Gateways with cap rails should have a good clearance to easily allow a person on horseback to ride through. Hessian or other lightweight material may be hung from the cap rail to discourage cattle from jumping over the gate.

Logs placed below ground level (bed logs) do not stabilise the gateway as effectively as cap rails, but require less post height and eliminate the need for cap rails.

Rigid attachment of the top fence rails to gateposts, and running the rails one or two panels back from the gates, help to give extra support to gateposts.

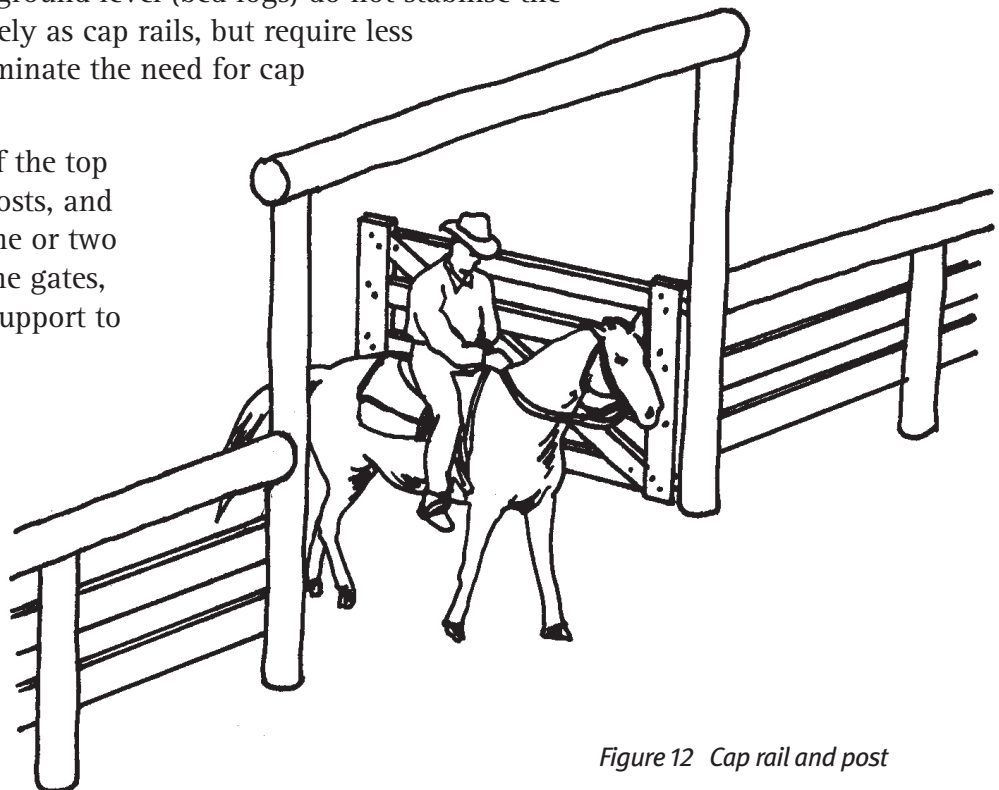

Figure 12 Cap rail and post

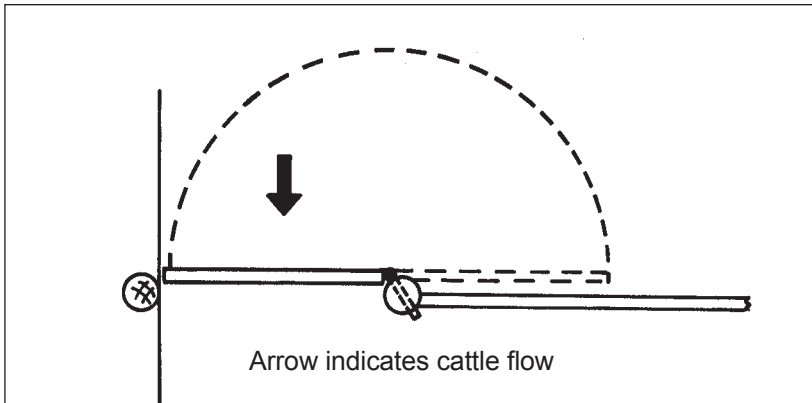

Figure 13 Correct gate swing

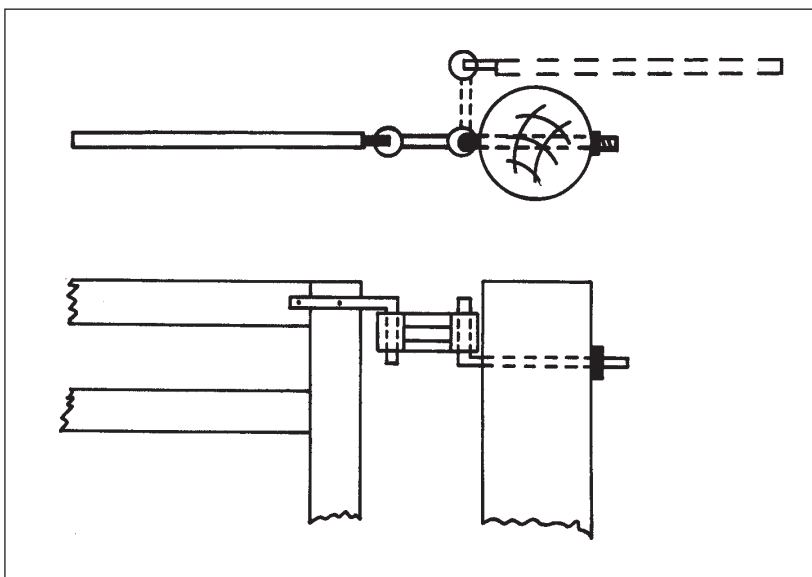

Figure 14 Two-way hinge

Swinging gates

All yard gates should swing back onto a fence line and latch onto a post when closed. Gates should open out in the opposite direction to which cattle are moving, especially when stock are being moved into small yards.

Gates through which cattle are frequently worked both ways are swung (hinged) using a two-way hinge to swing on the inside of the dividing fence (Figure 14).

If a gate swings both ways as in Figure 15, the gate is an additional bruising point and is continually buffeted by stock. There is greater risk of the operator being caught behind the gate with cattle rushing back and the adjoining fence provides little post support, so a cap is necessary.

Never swing a gate on the inside of the post on the dividing fence (Figure 16) unless a hinge is used that enables the gate to swing back 180° (Figures 13 and 14).

Gates hinged on the dividing fence (Figure 13) side are stayed by the rigid attachment of fence panels; they can assist with the final force of cattle through the gateway and there is less stock pressure on the gate and fewer bruising points.

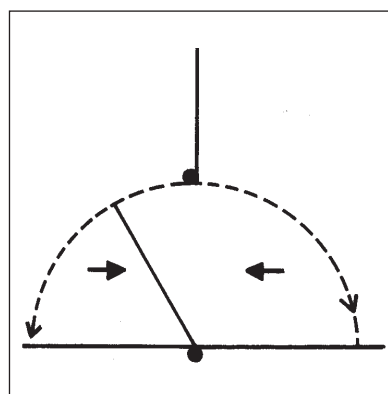

Figure 15 Gate swings both ways

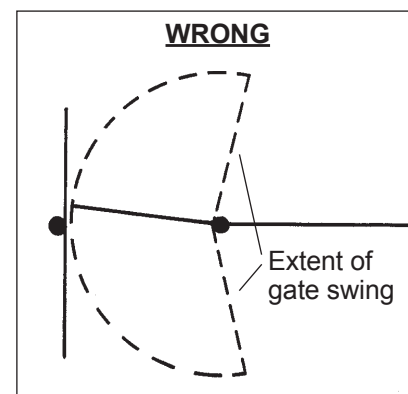

Figure 16 Incorrect gate swing

Hinges

Hinges should be strong and enable the gate to be easily removed for maintenance while preventing cattle from lifting the gate off the hinges.

Gudgeon-type hinges (Figure 17) are most commonly used for wooden gates. A threaded bolt is preferable to a spike on the gudgeon as it cannot pull out and is easily adjusted. To prevent cattle lifting the gate, either invert the top gudgeon or put a wire pin through it.

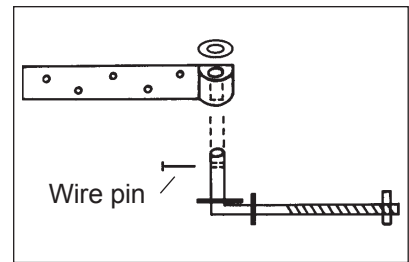

Figure 17 Gudgeon hinge

Block and collar (ring bolt) hinges (Figure 18a) for wooden gates are very robust, but need larger timber in the gate construction. The base of the gate pole is swivelled in a block of wood and a metal collar holds the top. Alternatively the gate pole can be extended and let into the gateway cap rail (Figure 18b).

There are various successful ways to swing steel gates. Metal collars (Figure 19) or a collar in conjunction with a gudgeon are common methods (Figure 20).

Corners on pipe or steel gates should be square (Figure 20). The top hinge should be as close as possible to the top of the gate to prevent animals getting their legs caught between the gate and the gate post.

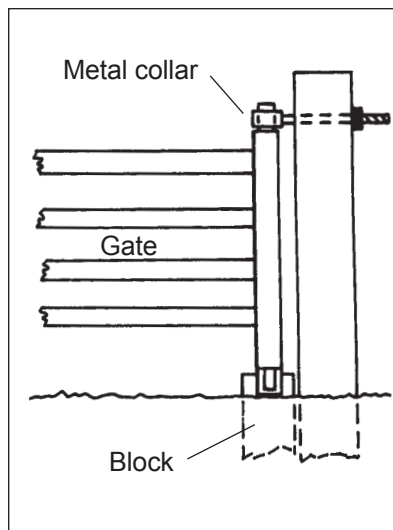

Figure 18a Block and collar hinge with metal collar

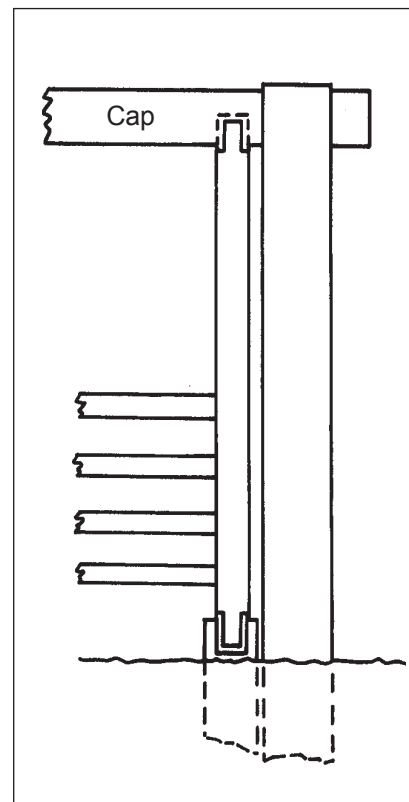

Figure 18b Block and collar hinge with extended gate pole

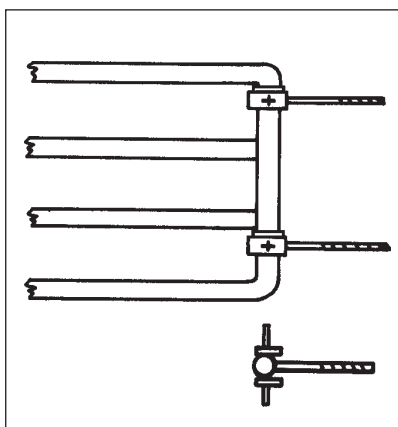

Figure 19 Pipe gate hinge with metal collar

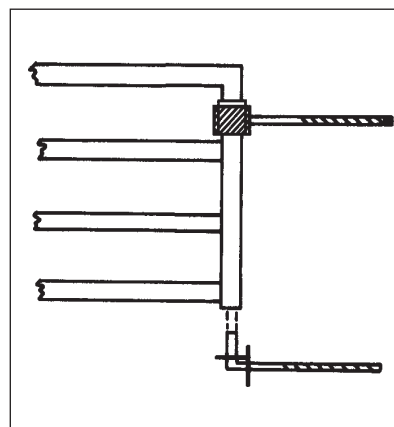

Figure 20 Pipe gate hinge collar and gudgeon

This catch is not recommended for use in cattle yards

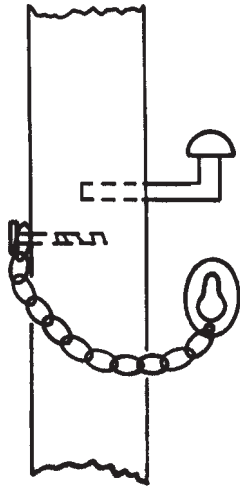

Figure 21 Chain and J-latch

Latches

Latches should be strong, easy and quick to fasten and unfasten, and not able to be worked open by cattle or horses. Several successful latch types are mentioned below.

A hook with heavy chain that wraps around the gate and latching post is often used. The chain is fastened to the post to prevent it becoming lost and to save time when fastening it.

A J-latch is not ideal for use in cattle yards but is suitable for a low-pressure gate (Figure 21), while the chain and notch is a more robust latch (Figure 22).

Wooden tongues and slots are convenient and provide a rigid latch; they are suitable for yard gates. This latch can bind in wet weather if not carefully constructed. The slot should be elongated to allow for gate sag.

With metal tongues use heavy gauge metal bolts as light gauge metal bends easily, causing latching difficulties. Bolt holes should be slightly enlarged to allow for sag.

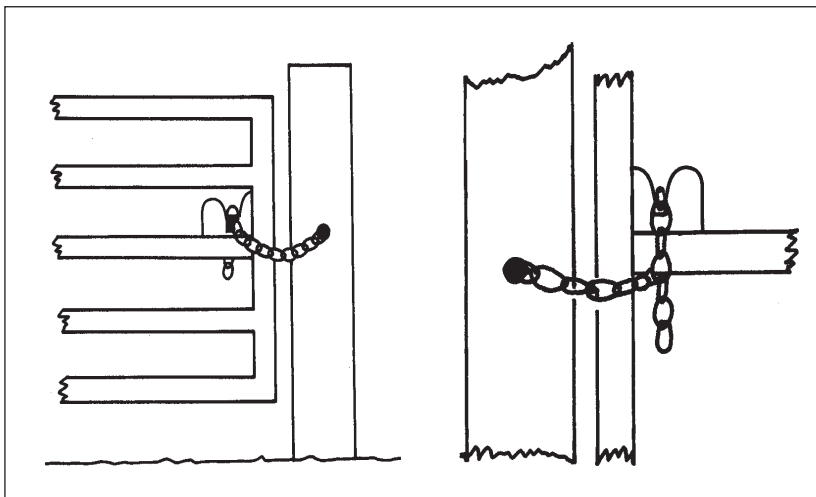

Figure 22 Chain and notch

Self-latching gates are useful, especially at the rear of the race. There are several types in both metal and wood but the most common is a pivoted tongue that rides over a notch (Figure 23).

The latches are easily opened by stock so a locking pin should be provided if stock are to be left in the yards.

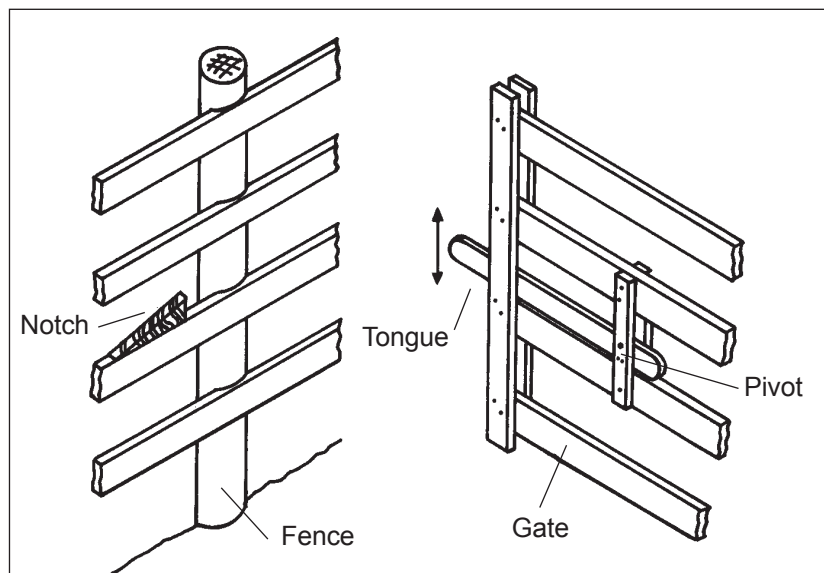

Figure 23 Self-latching gate

Figure 24 illustrates a spring return latch for self-latching gates.

Manways can save time and reduce operator fatigue when located in common traffic areas and properly constructed. Calves escape and older cattle get caught in incorrectly constructed manways.

Manways are preferably 400 mm wide and covered with a spring-loaded blank door that opens into the working yard and butts onto the post so it cannot swing through. A latch is required in case stock are to be held in adjoining yards. The manway opening should not exceed 500 mm (Figure 25).

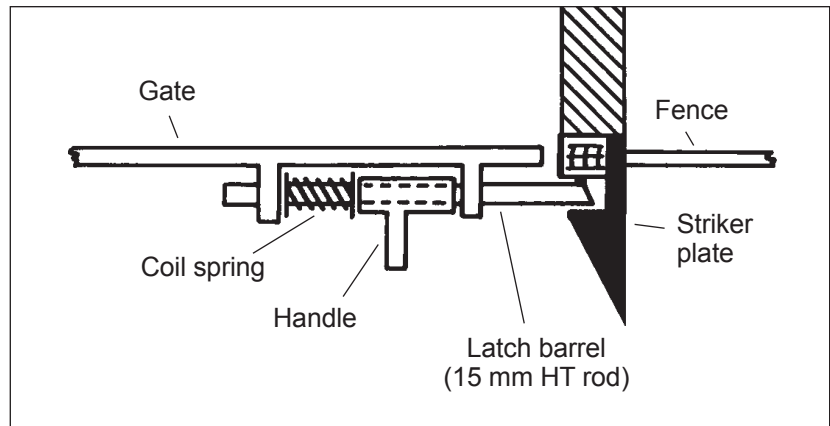

Figure 24 Spring return latch

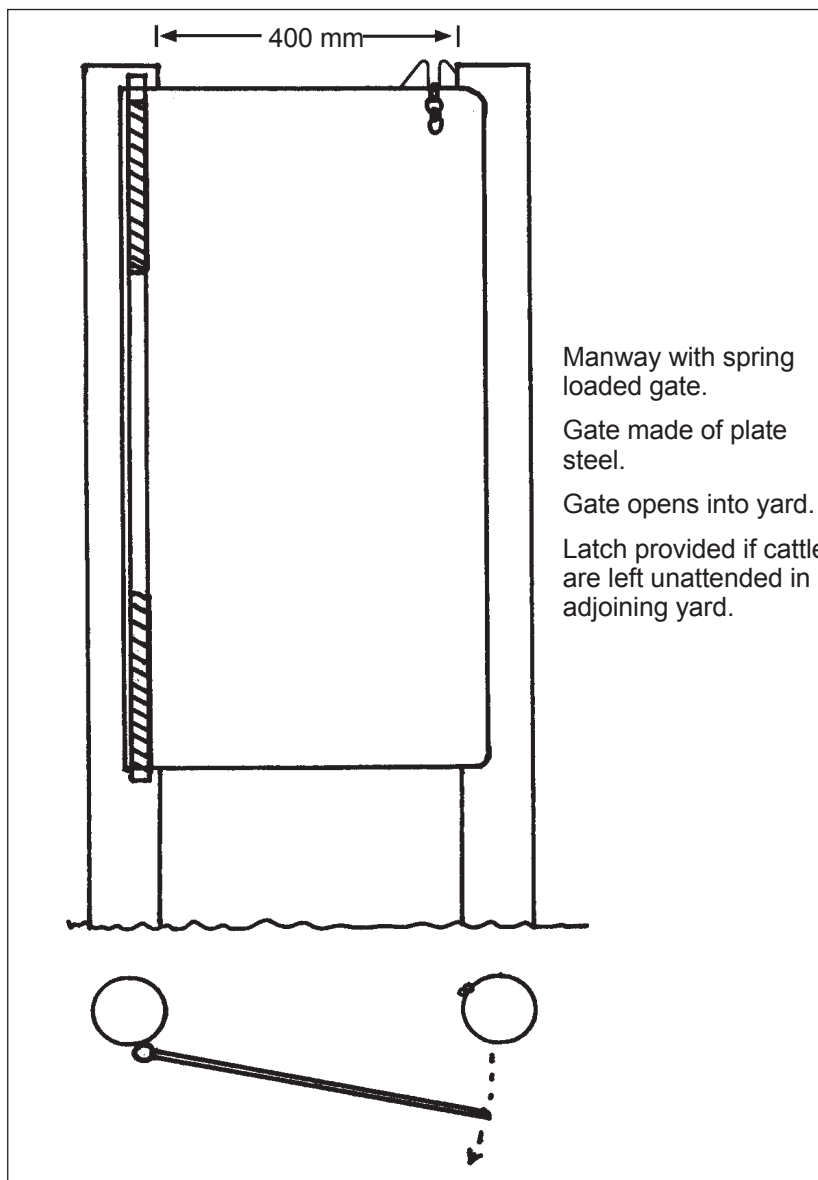

Figure 25 Manway

Yards within yards

The number of yards included in the overall plan will depend on the cattle production system and number of stock to be handled at one time.

Larger holdings may have a holding paddock from which cattle are worked into the receiving yard, then holding yard, forcing yard, drafting yard and pound. Radiating from the pound are the required number of drafting pens, a loading ramp, working race, veterinary crush and calf race.

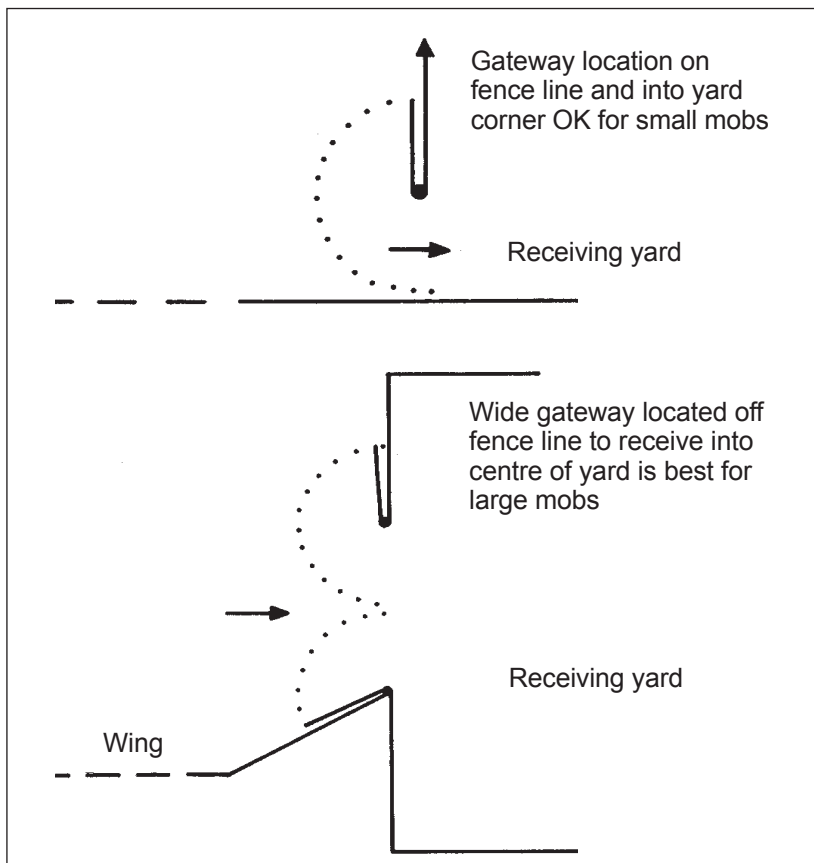

Figure 26
Receiving yard entrance gate

Receiving yards

The receiving yard is a deep yard to assist in 'drawing' the mob into the yards: cattle are difficult to force into small receiving yards. This yard is constructed of light material such as cables and a cap rail. The fence height is from 1.7 m for very quiet cattle to 2 m for more fractious cattle. To ensure sufficient space, allow 2.2 m per adult beast for the maximum number of stock likely to be handled.

The entrance gate to the receiving yard should be centrally located to encourage large mobs of cattle to draw into the yard (Figure 26). A split receiving yard helps handle large mobs (Figure 27).

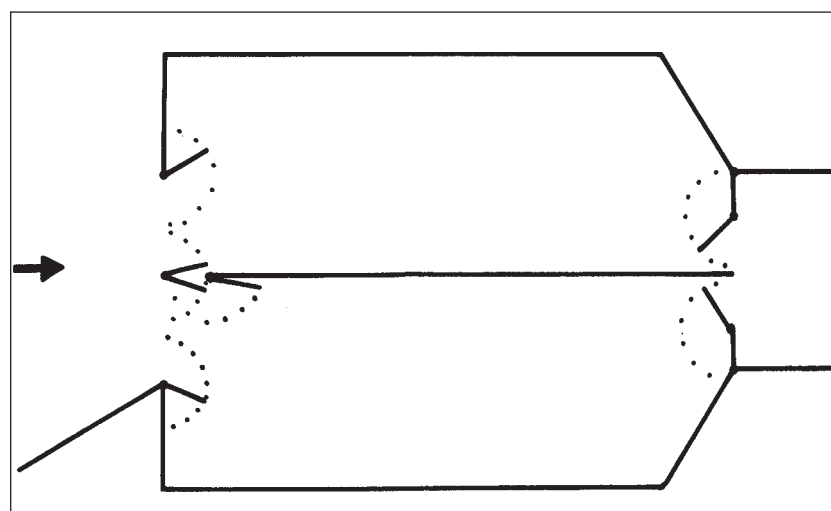

Figure 27 Split receiving yard

Holding yards

The holding yard is more solid in construction should provide an area of 2 m²/head. In smaller facilities the receiving yard doubles as the holding yard. Yards with curved fence lines tapering to the exit, such as the 'teardrop' shape illustrated in Figure 28, are usually easier to work cattle in.

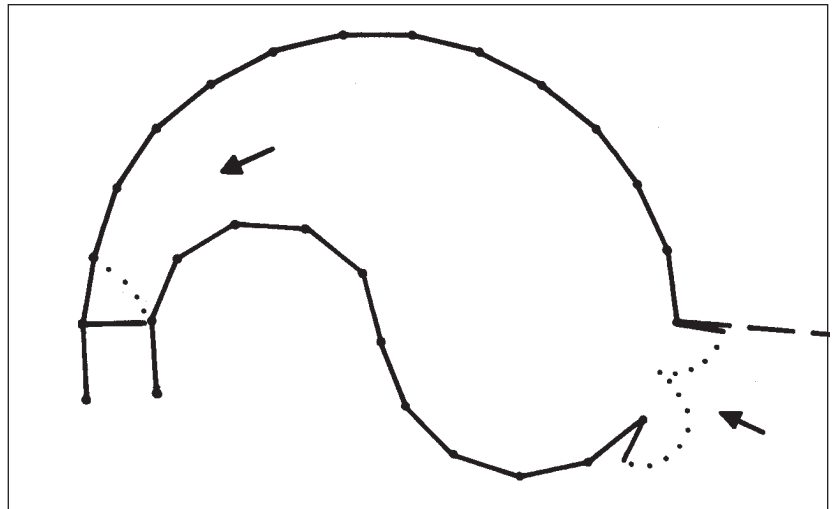

Figure 28 Teardrop yard

Forcing, drafting and cooling yards

The forcing yard is constructed of solid material in line with the requirements of close-working yards. Cattle tend to jam in forcing and drafting yards with square or tight corners. Remove or modify such corners. Cattle are difficult to force in yards wider than 6 m and wider yards require two or more people to operate. The forcing yard should preferably taper towards the exit (Figure 29).

Sheeting the sides of the forcing pens removes distractions and focuses animals into the crush.

Visual barriers at the rear of forcing and drafting yards discourage cattle from trying to get back to their mates. The gate must also provide a visual barrier.

The drafting yard has a maximum width of 6 m and tapers towards the pound entrance. Optimum length is 9 m, maximum 12 m. This solid yard provides 1.8 m² per head for 20 to 30 head.

The cooling yard has a water trough and is a shady yard of light construction for cattle to spell in before the mob is returned to grazing. Minimum area per beast is 2.5 m².

Figure 29 Forcing and drafting yard shape

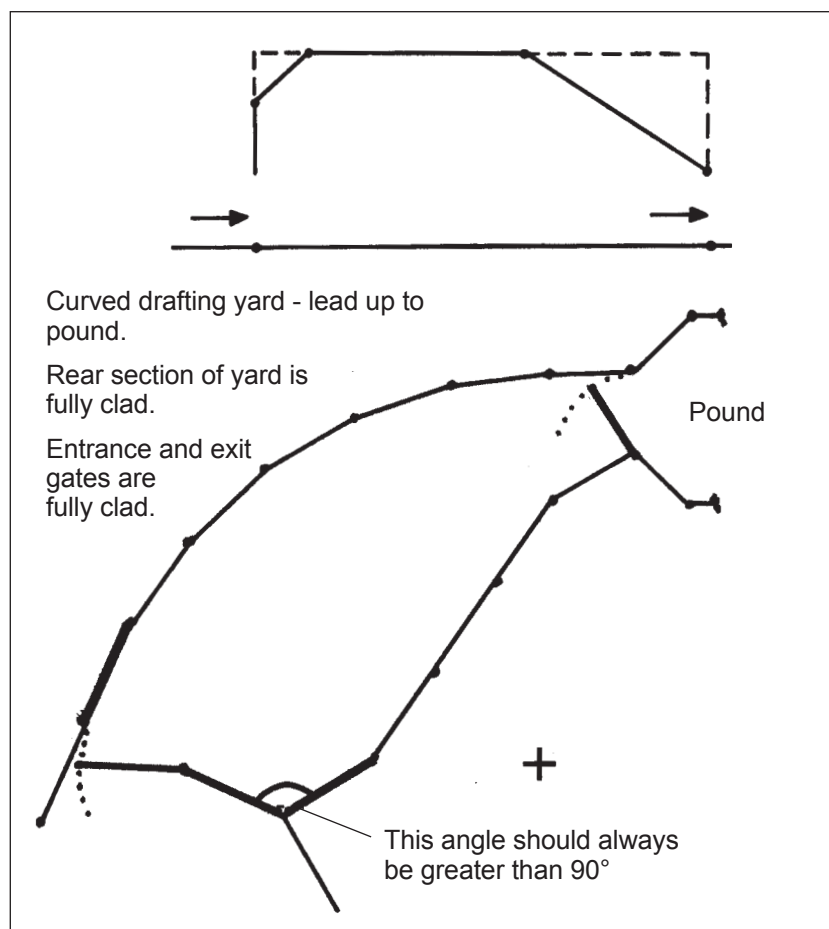

Drafting

Drafting or sorting is a necessary part of cattle management. Traditionally, drafting was carried out on horseback on a 'camp'. Horses are still valuable for paddock drafting or drafting a few head from a large mob without having to run the whole mob through the yards. Major drafting operations are conducted in the yards. This requires fewer handlers, and yards are the venue for most other cattle handling operations.

Common drafting requirements are to sort calves from cows for branding; finished cattle (tops) from unfinished (tails) in finishing operations; bulls from cows; or weaners from cows.

Drafting can take place in a drafting yard, in a pound or in a race. The size of the pen into which cattle are drafted depends on the herd size. If there are large numbers to be drafted off they are first drafted into a small pen and then released to a larger holding area. This practice saves time if mis-drafts occur. Drafting difficulties occur if the drafting yard or pound is overcrowded.

Yard drafting is slow and often not suited to large herds, especially if the mob is to be split three or four ways. The drafting yard is commonly used in conjunction with a pound. Selected cattle are drafted into the pound, then the appropriate pound gate is opened for the stock to enter the chosen drafting pen. This practice enables one-person drafting.

Alternatively, a small number (about 10 head) of stock are put in the pound and the drafter operates in the pound, sorting stock into the various pens. Yet another way is for the pound gates to be operated remotely from a platform by connecting poles.

CAUTION: Poles attached to drafting gates can cause serious operator injury if the operator is standing in the path of the pole when a beast forces a gate open. Drafting stock in the pound is often slower and more dangerous than drafting into the pound.

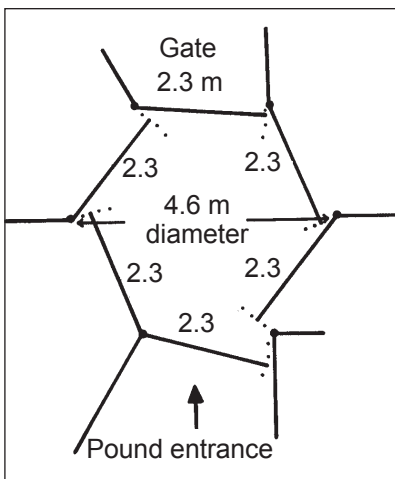
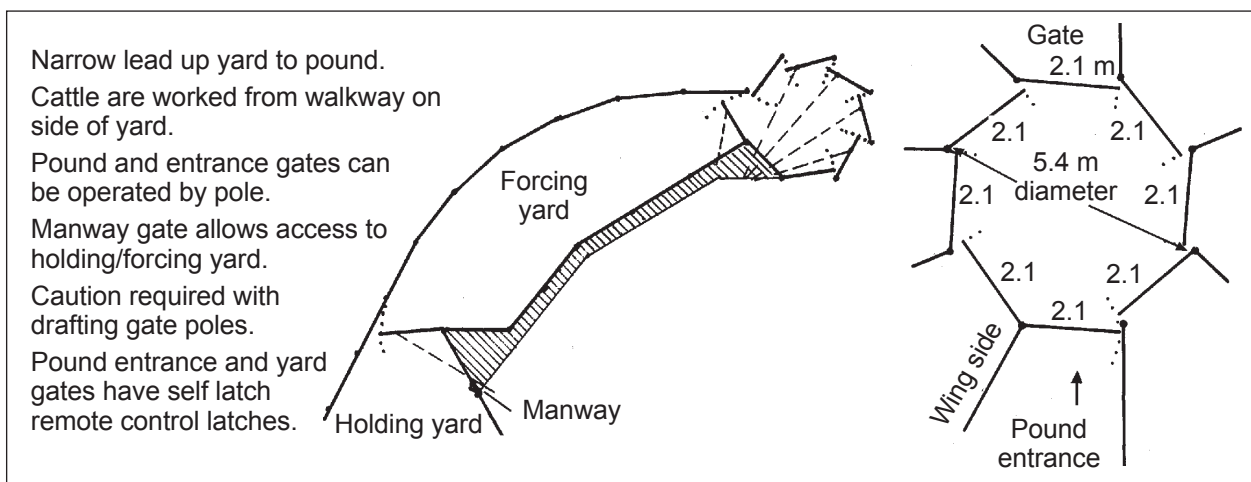

Figure 30 Hexagonal pound

Figure 31 Octagonal pound



Octagonal or otherwise rounded pounds are better as cattle tend to jam in corners of square pounds. Hexagonal pounds are satisfactory in smaller yards. Square pounds increase stress in cattle and drafting takes longer.

Pound size depends on many factors, including personal preference. If cattle are drafted into the pound, a diameter of 5.5 m is ample. Larger pounds up to 7.5 m diameter are sometimes used if cattle are drafted in the pound. Pounds should be small enough to make cattle look for a way out.

Exit gates to drafting pens are 1.5 to 2.2 m wide, gates to the loading ramp and main race forcing pen 1.8 to 2.2 m and entrance gates 2 to 2.4 m wide. Gate construction should present a blank appearance without creating a dark area. Gate lengths are measured from the centre of each post.

The entrance gate to the pound is swung from the post on the wing side (Figure 31) of the drafting yard and opens outward. All gates should open into the pound except the entrance gate from the forcing yard.

When an overhead lever system is used, the levers are attached to an extension of the gate upright and operated from a platform. This platform is best located just outside the pound near the pound entry gate.

Pound examples are shown in Figures 30 and 31.

Drafting races are an alternative to pound drafting and are easily incorporated into existing races. Mobs can be split into groups depending on requirements. Cattle flow is maintained and it is usually quicker than pound drafting. The operator does not get as good a view of the stock, especially if remote controls are located above the race. A block gate is required to block or steady cattle flow. This gate is normally a sliding gate although other forms of race gates are suitable (see section on race gates). Race drafting is helped if the lead-up race is longer than 8 m.

A pound is not necessary with race drafting but some form of yard drafting will be required, especially with one-person operations.

Race-drafting gates open into the race and are of open construction to reduce weight and not impede cattle vision. Figure 32a shows a three-way draft that can be incorporated in to the working race of a small yard. Figure 32b illustrates a four-way system.

Drafting can be conducted from a platform above the race or by a lever or pulley and cable system located at the side of the race. Gates are returned to the closed position by a double-acting lever and cable system. The block gate can also be cable controlled.

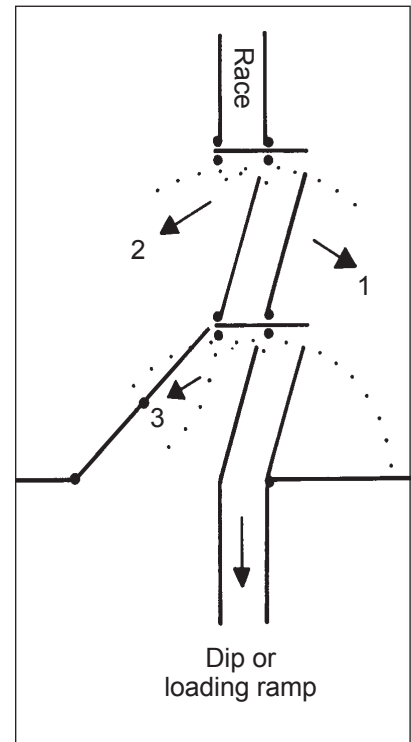

Figure 32a Three-way race draft

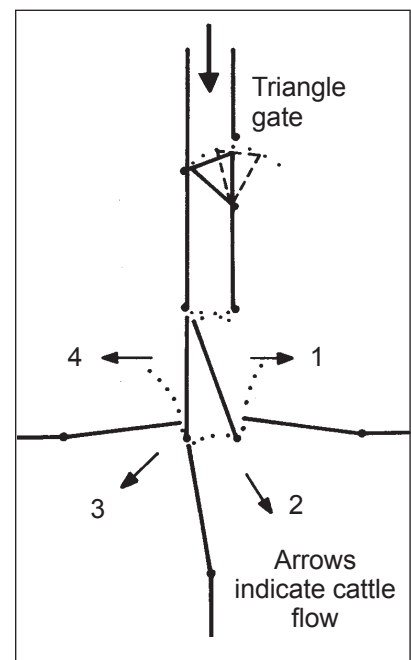

Figure 32b Four-way race draft

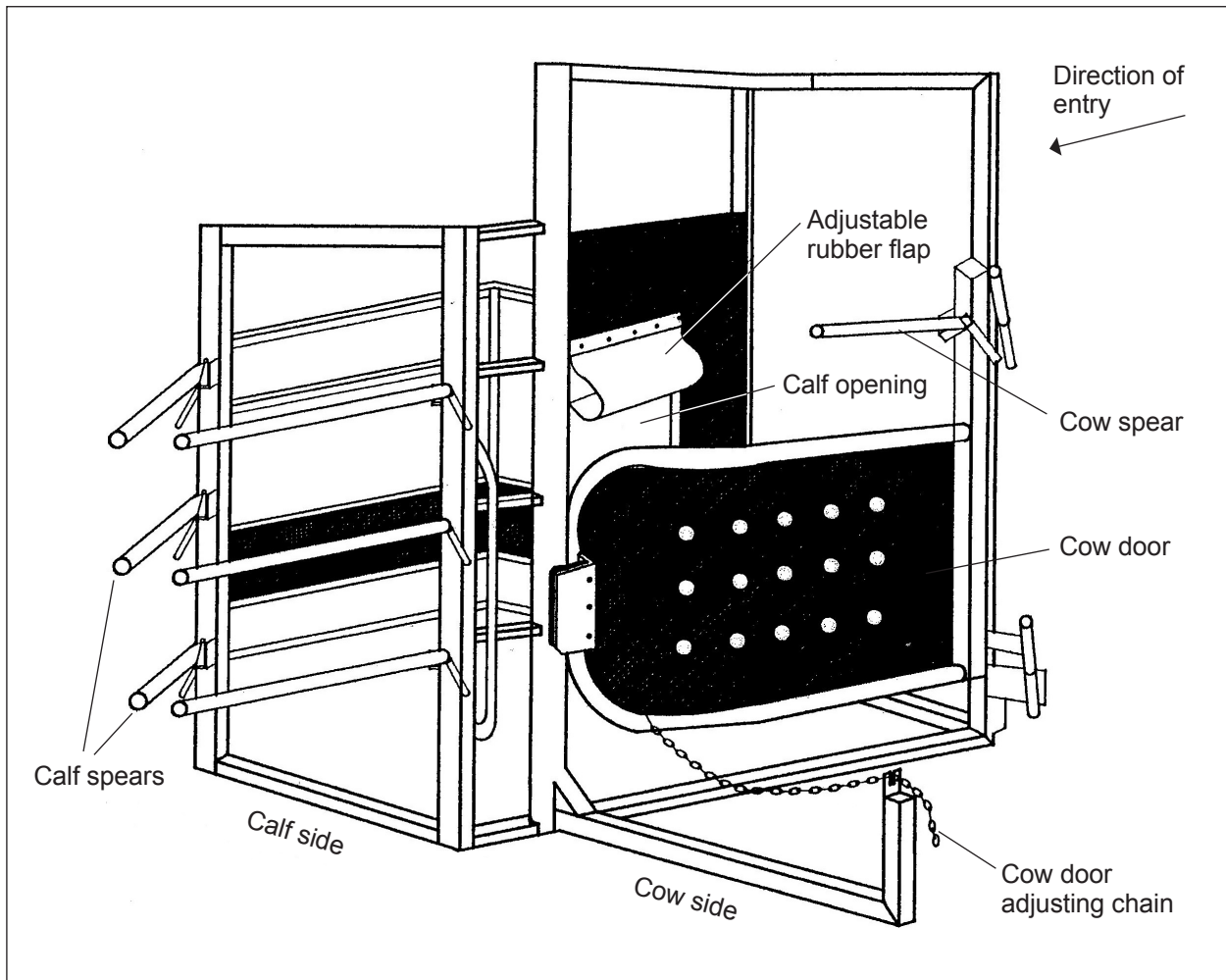

Figure 33 Cow/calf separator

Cow/calf separator

This system is designed to operate in conjunction with spear gates that have been constructed for holding enclosures around watering points. It self-drafts calves and weaners from cows into a holding yard for branding and weaning.

The system reduces the need to perform traditional musters, improving the efficiency and cost effectiveness of management. Handling time and stress on both operators and animals are all reduced. This system of separating cattle means that a number of weanings can be carried out during the dry season, depending on seasonal conditions and herd health. Weaners can be removed at the optimal time, reducing lactational stress on breeders and the management problems and supplement costs associated with early weaners.

To install a cow/calf separator, all waters in a paddock must be fenced, and separators and spear gates of the same type installed at each location. This ensures that all cattle become familiar with separator and spear use, and are able to access water at every point in the paddock. Enclosures should be sufficiently large to allow most, if not all, of the cattle to

'camp' (rest) within the enclosure during the day.

The best position is a well-used pad using a combination of a spear gate and a separator for the entry and exit from the water point.

These two arrangements have both advantages and disadvantages.

Separator In, Spear Out

With this configuration, at the time of trapping, animals will be held in the water enclosure itself, and it is therefore possible to determine whether or not the whole mob has come through and have been caught. It may also be an advantage for calves, after processing, to be released to their mothers in the water enclosure as it may be easier for them to find their mothers. The main disadvantage is that 'stranger animals' (those that have entered the paddock from elsewhere and are unfamiliar with separators and spears) may refuse to pass through the separator to water (because of the noise of the cow-door as it shuts, etc). Therefore, there is the risk that they may perish.

Separator Out, Spear In

With this set-up, there is less risk to 'stranger animals', as they are more likely to pass through a spear than the separator to water. Another advantage is that these strangers, and any other animal that will not use the separator, will be held in the water enclosure, and can easily be identified. Also, at the time of trap-mustering, they will be caught more easily for processing. However with this configuration, it is more difficult to assess whether or not the whole mob have been through the separator. Another drawback with this arrangement is the possibility of mis-mothering. After processing, if calves are released out to the paddock rather than the water enclosure, they may be less likely to find their mothers.

Breeder animals (heifers/cows and bulls) must be trained to push open the cow-door to access or exit the water point enclosure. Initially, use of the calf side simply relies on choosing a clear visual route. With repeated use of the separator, calves will actually learn to use the calf-side.

Training of breeders should be done before calves are born, and with bulls and heifers, this can be in cattle yards when they are weaners, or in the paddock.

The door on the cow-side closes behind the cow forming a barrier to the calf, but the open calf-side provides an easy passage for it.

Young animals that will be retained in the herd for breeding will require some re-training.

The spears should be put in place on the calf-side 2 to 3 weeks prior to trapping so that the animals get accustomed to pushing through them.

Trapping simply involves setting up a calf yard, using portable panels, around the calf-side.

When using separators, all reasonable measures should be taken to prevent cattle unfamiliar with the separator system from entering the paddock (e.g. from neighbouring properties or paddocks with unfenced water).

Pneumatic drafting

Pneumatic or hydraulic systems can also be used to draft cattle in races. They are mostly used to draft cattle into pens from a veterinary crush following treatment such as weighing, pregnancy diagnosis, dehorning, implanting hormone growth promotants (HGPs) or some other management practice.

Many gates can be operated from one central point, thus enhancing animal welfare by reducing the time taken to process individuals and groups of animals. Gate control can be either manual or computer-driven. These drafting systems can be modified to suit either permanent or portable yards.

Automatic computerised drafting using specific data inputs is readily achieved with all records able to be stored for later use as the need arises.

Air compressors should be sited away from areas where animals are worked to reduce stress from noise.

Forcing pens

The forcing pen should be of solid construction and preferably fully cladded. Full cladding will make a dark area which cattle may not readily move into unless the race entrance is obvious. One side of the pen should be in line with a side of the race and the other at an angle of 30 to 35° to the side of the race. Wider angles make forcing difficult and narrower angled forces tend to cause cattle to jam. The gate at the back of the forcing pen should present a visual barrier and be 1.8 to 2.2 m wide. The pen should be no wider than 3.5 m and from 4 to 6 m in length. A self-latching swinging gate or sliding gate is good at the race or ramp entrance.

The approach to the race is straight or curved but one side should lead into the race (Figure 34).

A manway to the forcing pen is a good idea as it is often the most frequently used yard. Avoid creating corners where stock are likely to jam.

Several variations of traditional forcing pen designs are illustrated in Figures 35 to 37.

The layout in Figure 36 is mostly used prior to the loading ramp and the waiting bay holds 0.5 to 1.0 deck loads of cattle.

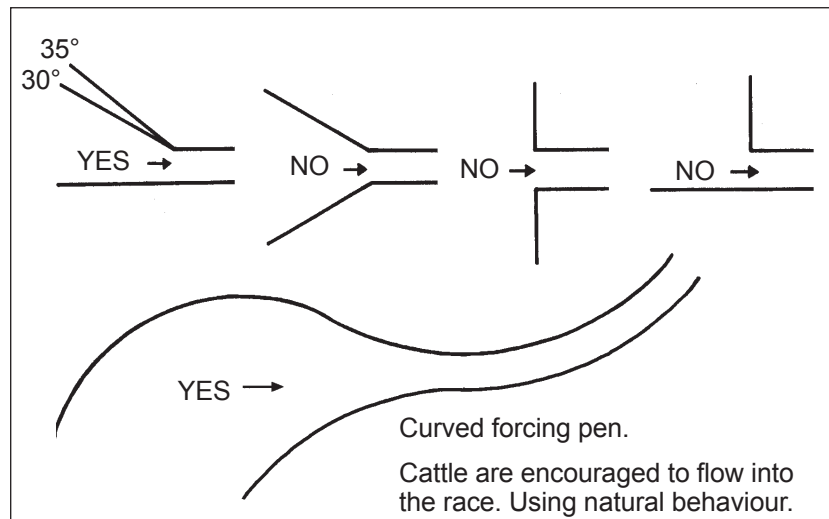

Figure 34 Forcing pen exits

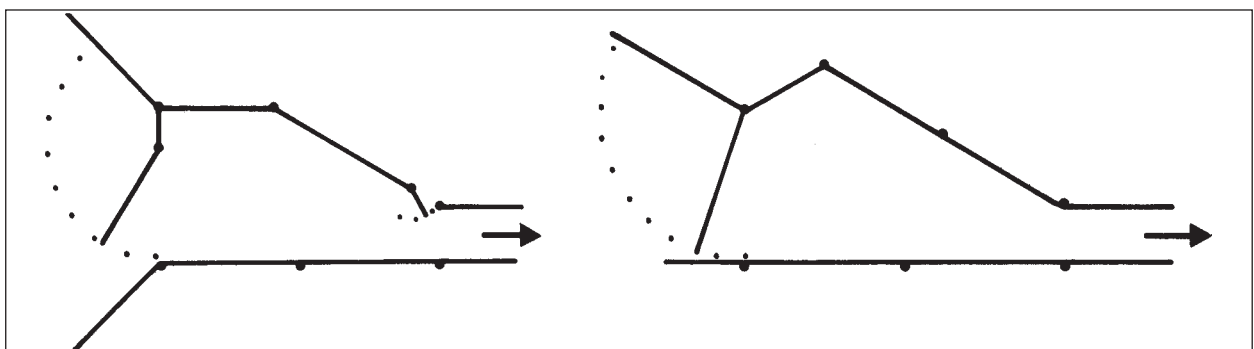

Figure 35 Conventional forcing pens

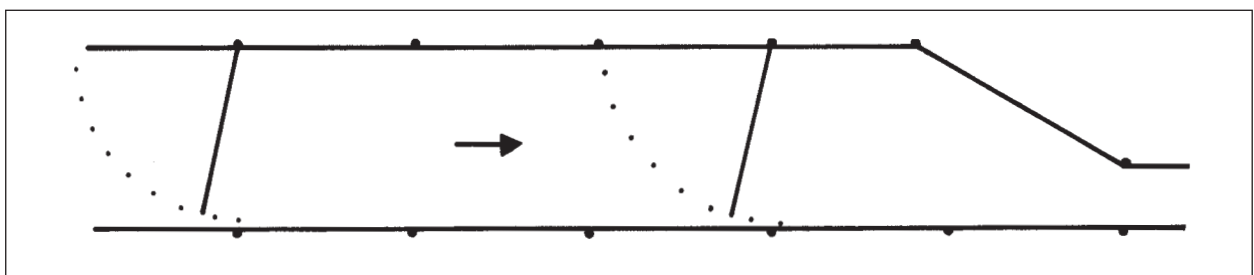

Figure 36 Forcing pen with waiting bay

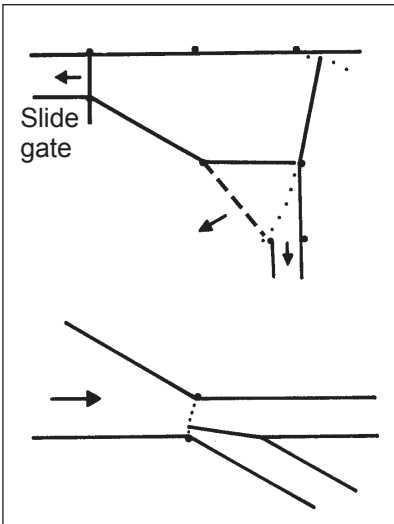

Figure 37
Dual-purpose forcing pens

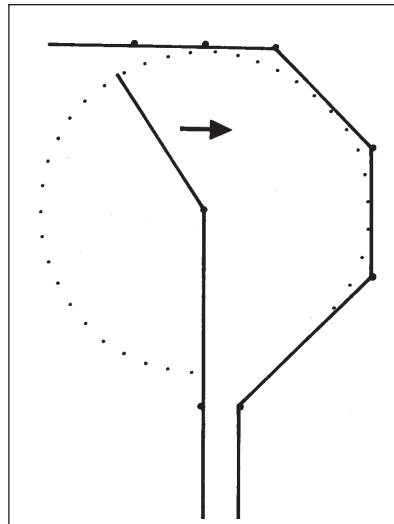

Figure 38
D-shape forcing pens

Circular and D-shape pens (Figure 38 and 39) are more efficient in some situations. The centre post is constructed of 200 mm bore casing and the gate hinges are on flat steel collars enabling rotation in circular forcing pens (Figure 40).

In Figures 38 and 39 the gate should be equipped with a ratchet latch to prevent the gate being forced back onto the operator.

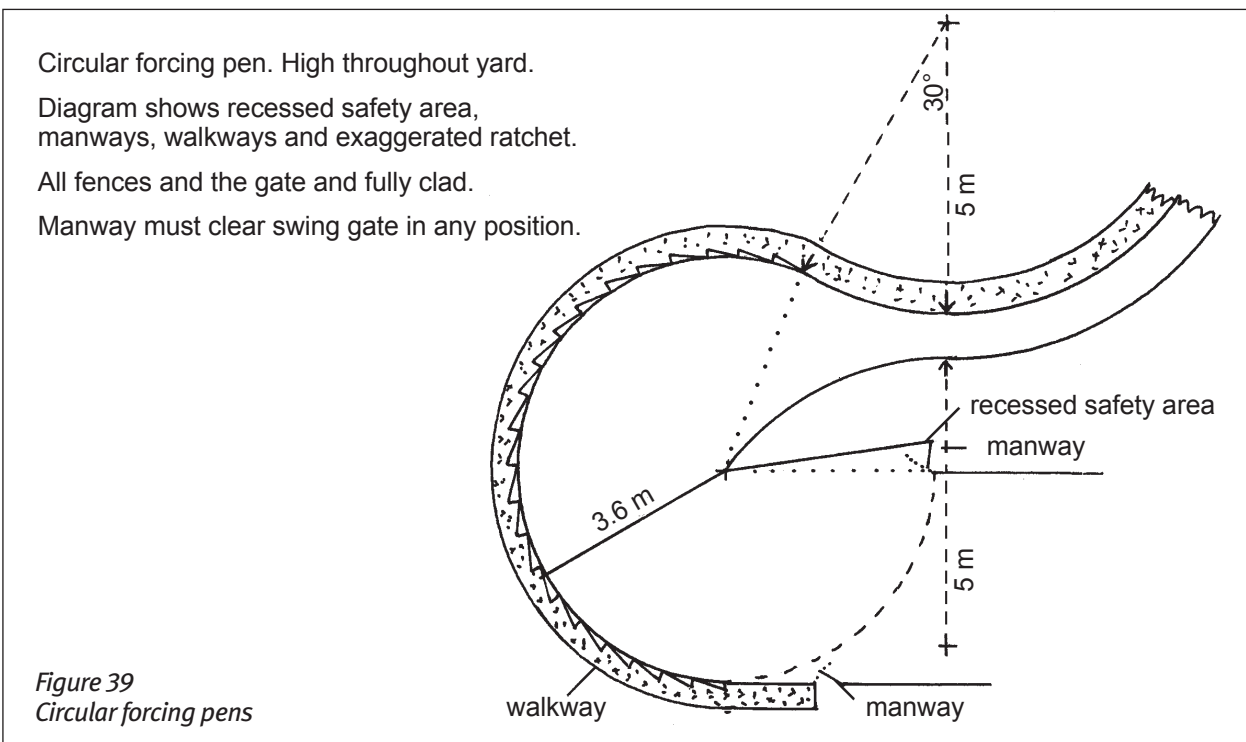

Figure 39
Circular forcing pens

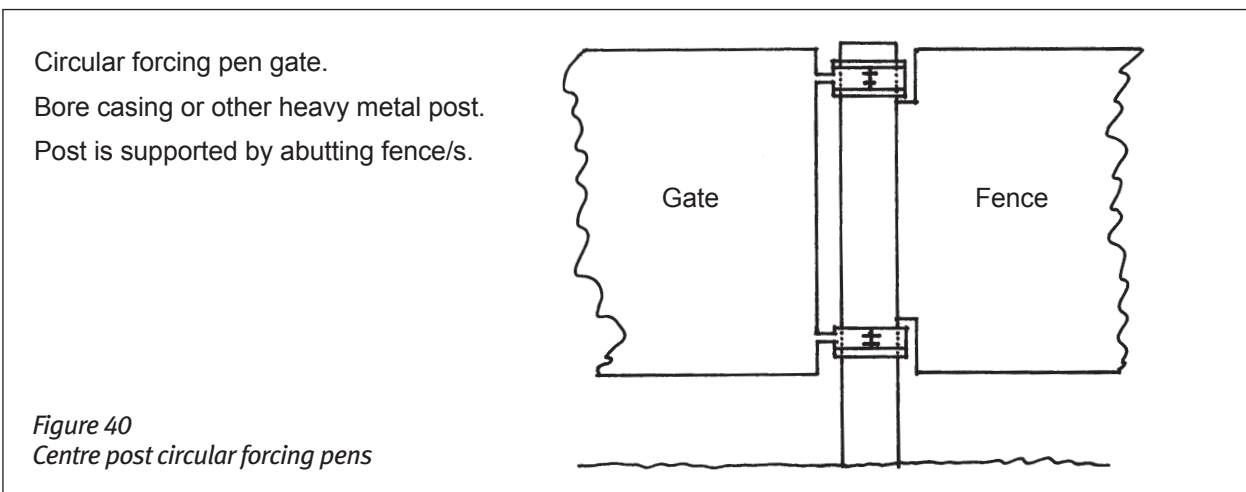

Figure 40
Centre post circular forcing pens

Races

A race is a necessary part of all cattle yards and many operations are conducted in them, such as vaccinating, disease testing, cross branding and drenching. The race also provides a lead-up to the veterinary crush, dip and race drafting gates. Some cattlemen prefer a separate dip lead-up race but it is not necessary.

Badly constructed races make cattle handling an arduous, time-consuming and dangerous task.

Cattle need to see where they are required to go and will generally draw better into races longer than 8 m. Races longer than 12 m can delay working if a beast turns around, as often the remaining stock have to be backed out. Races longer than 15 m should have a block gate located midway along the race.

Race panel length is 2 to 2.4 m. A guide to total length (excluding the veterinary crush area) is:

Number of cattle in mob	Minimum race length
1 - 10	3 m
10 - 50	5 m
50 - 150	7 m
150 - 300	8 m
300 +	12 m

Longer races are often used for disease-testing very large numbers.

Vertical-sided races have an internal width of 680 mm, up to 700 mm for large European breeds. V- or tapered races as illustrated in Figure 41 should have an internal width of 450 mm at the ground and spread to 690 to 700 mm, 1 m from the ground. The remainder of the race panel should be vertical to enable easier operator-animal access. The 'V' section in Figure 41 should be fully cladded.

Stabilise race posts by setting them 1 m in the ground and concreting in place. Posts can be stayed across the race in several ways. One method is a brace under the ground,

Figure 41
V-race internal measurements

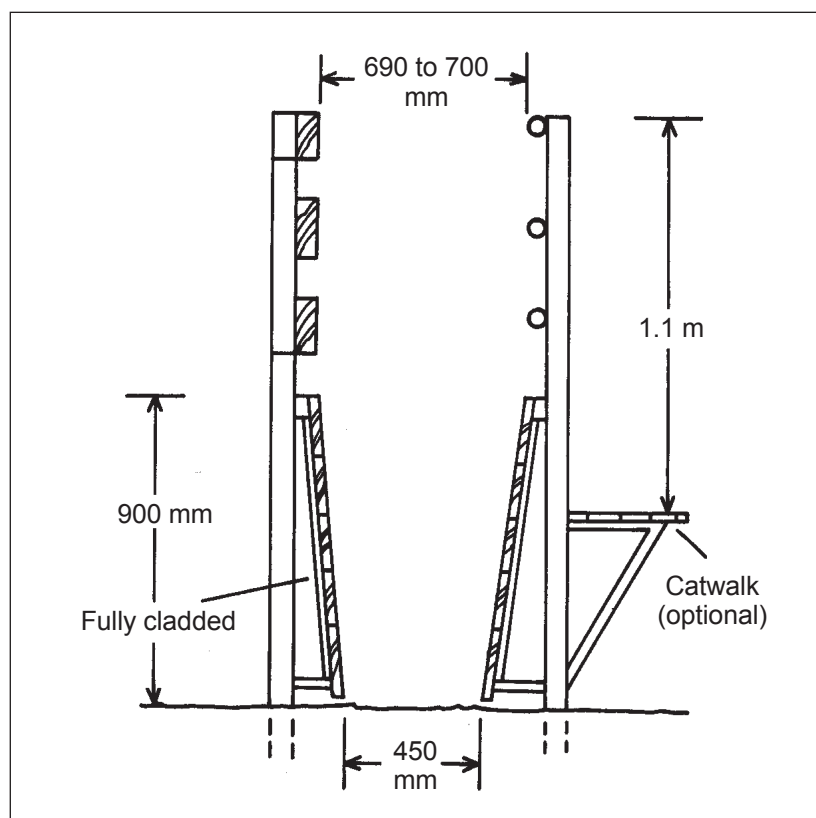

thus avoiding the use of overhead structures. Another method is to stay the posts across the race a minimum 2.2 m above the ground using a cap rail or metal tie. Metal ties tend to create less baulking. V-races are more difficult to construct and stabilise than straight-sided races. Round timber caps running lengthways increase stability, however they are difficult to work over.

A concrete race floor reduces dust, bogging, dip pollution and erosion problems. The concrete should extend at least 200 mm either side of the race to prevent feet getting caught between the bottom rail and the concrete. Grooves 50 mm wide and 25 mm deep at 250 mm centres are made in the concrete to reduce slipping. The concrete floor should preferably extend 2 to 3 m from the working side of the race to provide a working apron.

Race-top rail height is 1.7 to 2 m depending on cattle size and temperament. Spaces between rails in open-sided straight races are, from the ground up, 280 to 300 mm; 230 to 250 mm; 250 mm; 280 mm above that. Spacings are similar for wooden or pipe rails (Figure 42).

Figure 42 Open vertical side race

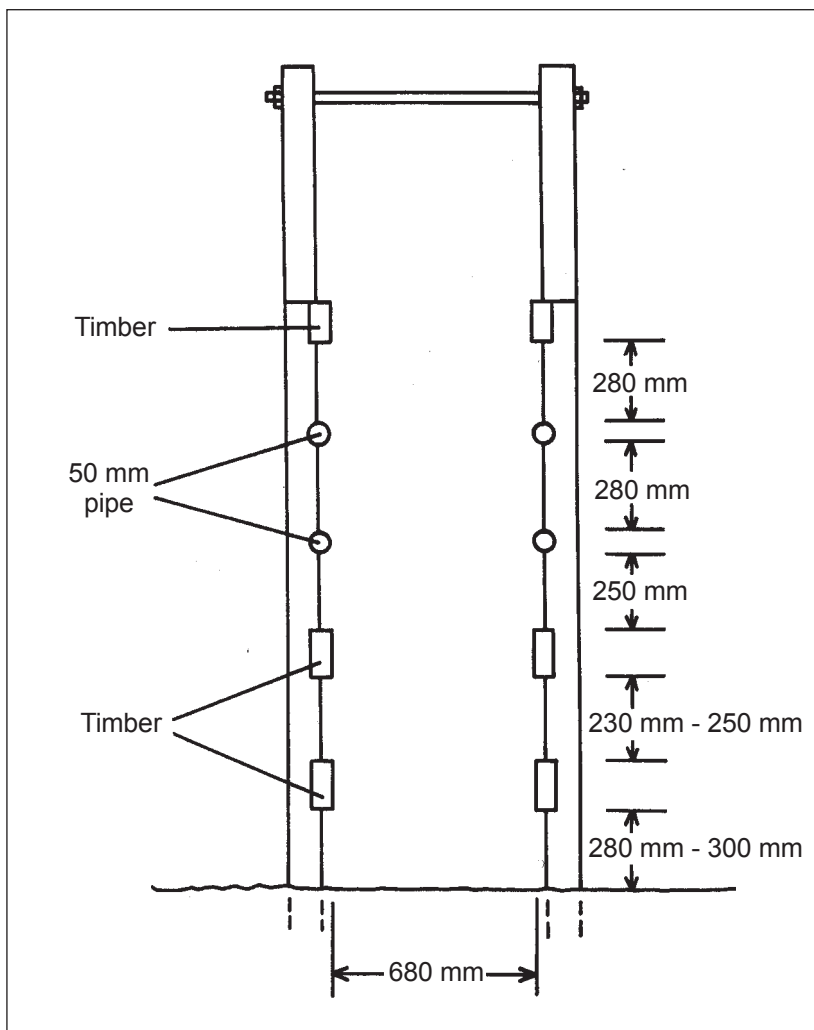

Round timber rails (130 to 150 mm diameter) or sawn timber (130 to 150 x 50 mm) can be used for the top and bottom two rails. The third and fourth rails from the ground (working height) should be round timber or preferably 50 mm pipe (Figure 42). Pipe, cattle rail, or round timber rails are more comfortable to work over than sawn timber.

Rails are fastened by wire twitch, U-bolts, or hexagonal bolts with nuts countersunk on the insides so they can be removed easily if a beast goes down. Cut the end off the bolt, flush with the nut, to prevent injury to either animals or people. The bottom pipe rails should not be welded if steel posts are used and shallow mortices only are used on timber posts. Avoid projections that

can bruise stock or injure the operator.

To help prevent cattle getting wedged if they go down, V-races are built with smooth, fully clad sides for the bottom 900 mm (Figure 41). V-races reduce turning problems when various size cattle are worked but are more difficult to construct and work over. Unless the bottom 900 mm of V-races are blanked, stock tend to put their legs through the rails and get wedged more easily if they go down. The bottom two rails can be hinged for easy release if animals go down.

To partly overcome the problems in working over V-races, a catwalk or walkway can be constructed on the working side (Figure 41). The height of the walk is 1.1 m below the top rail height. Catwalks often get in the way of an operator inspecting for ticks. Catwalk surfaces should be non slip and allow dirt to fall through rather than build up. On timber, netting can be attached to improve the grip. Extruded steel is excellent.

Cattle work well in races that are fully clad on the non-working side and clad to a height of 900 mm on the working side. However, cladding on the working side is not suitable for many properties where stock are held in the race for cattle tick inspections. Fully clad race walls can be constructed of sawn timber, plate steel, heavy-duty ply or conveyor belting.

Cattle move more freely and tend to reverse less often in a curved race than in a straight race as they tend to follow the outside fence around. The operator works on the inside curve, resulting in better cattle movement and less walking for the operator. Curved races should have an inside radius of about 5 m.

Adjustable-width races reduce turning problems. However, they are practical only where large numbers of similar-sized stock are being handled at one time. Some adjustable races tend to increase noise and reduce the robustness of the structure.

Structures such as fences and calf crushes built on to either side of the main race hinder the operator. If there is a need for a fence to butt the race, the closest panel should

Figure 43 Fence abutting race

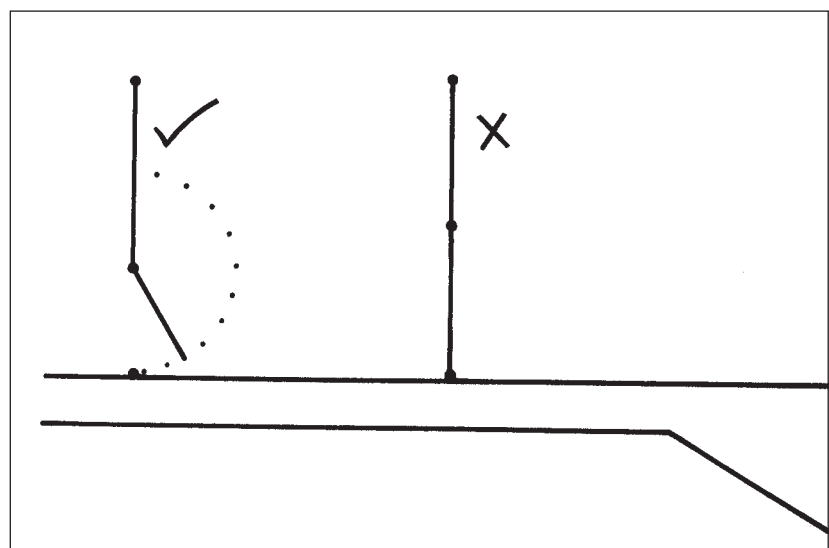

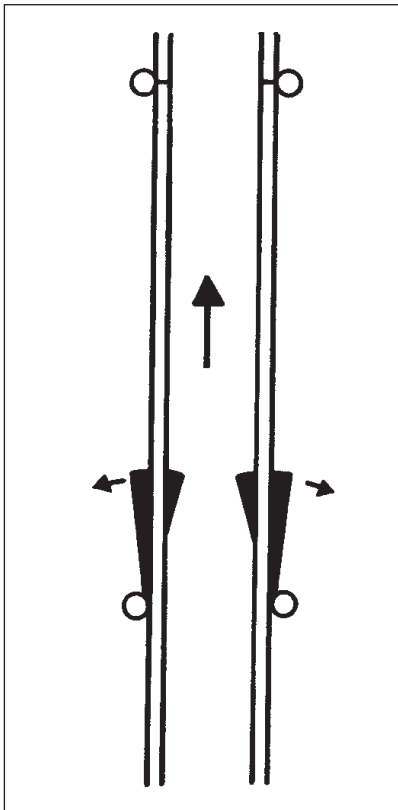

Figure 44
Batwing anti-backing gate

be a gate, latched to a post on the race side (Figure 43).

Batwings (Figure 44) can be used in races to prevent backward movement but can also impede cattle flow. They are pivoted on both race sides, and swing out as a beast moves through; a spring returns the wing to the closed position. The wings are set 600 mm from the race floor and when closed occupy half the race width.

Flapper gates (Figure 45) work on a similar principle but are pivoted 300 mm above the backline of the animal. As the beast moves under the gate it swings up and returns when the beast has passed. The flapper is counter-weighted to reduce resistance and noise. The rump rail height is adjusted to 150 mm below the animal's rump.

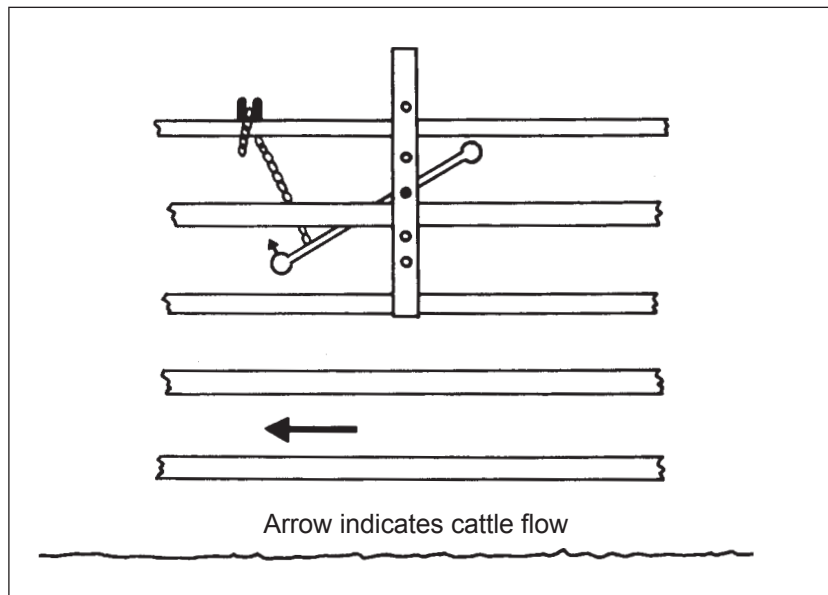

Figure 45
Flapper anti-backing gate

Race gates

Gates across the race are required at the entrance to prevent stock backing out or others moving in. Use them midway in races longer than 15 m, to block the flow of cattle for race drafting and holding stock in the veterinary crush area to protect the operator from animals behind.

Sliding gates are effective and most commonly used. There are other types of race gates such as A-frame gates, triangle gates and L-gates. Whichever is used it must open to the full width of the race.

Race gates dividing the race midway and at the entrance to the race should be of strong but open construction. The principle is to let the animal see those in front but at the same time present a visible barrier. These gates are made of horizontal pipe or sawn timber with 200 mm maximum space between rails. Cattle tend to open sliding gates with vertical rails unless the gates have locking devices.

The entrance gate to the veterinary crush should be sheeted to provide a visual barrier so that following animals do not see what is happening in the crush and cannot reach the operator.

Slide gates are made of 38 mm pipe (minimum) or 150 mm x 25 mm boards. If required, pipe constructions are blanked with belting or sheet metal. The width should be such that the edge is flush with the outside of the supporting race posts when the gate is closed. The gate handle should be the only protruding part. Gates should run 150 mm above the race floor and have a minimum height in line with the top rail of the race.

Slide gates can be carried on pipe, wood or other steel rails at least 2.2 m above the race floor. Posts are set so that the gate fit is snug but not tight enough to impede gate movement. Gates can be supported between two high posts (Figure 46), or one high and one race-height post (Figure 47).

Slide gates can run on metal straps running over a 50 mm pipe (Figure 48), on sealed bearings, or rollers of nylon or steel (Figures 49, 50, 51 and 52). A line of weld strategically placed prevents bearing gates being vibrated open.

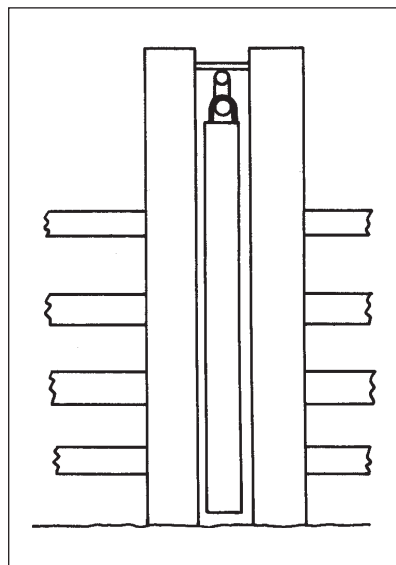

Figure 46 Two post support

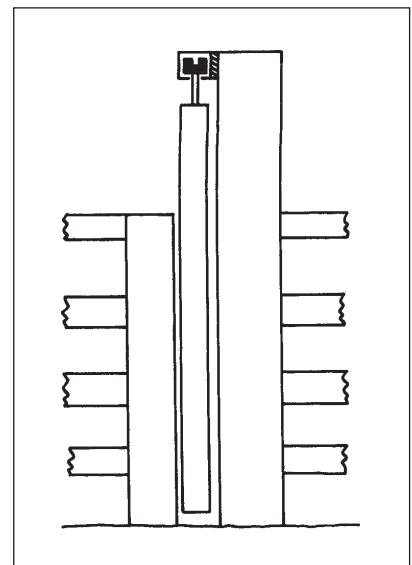

Figure 47 Single post support

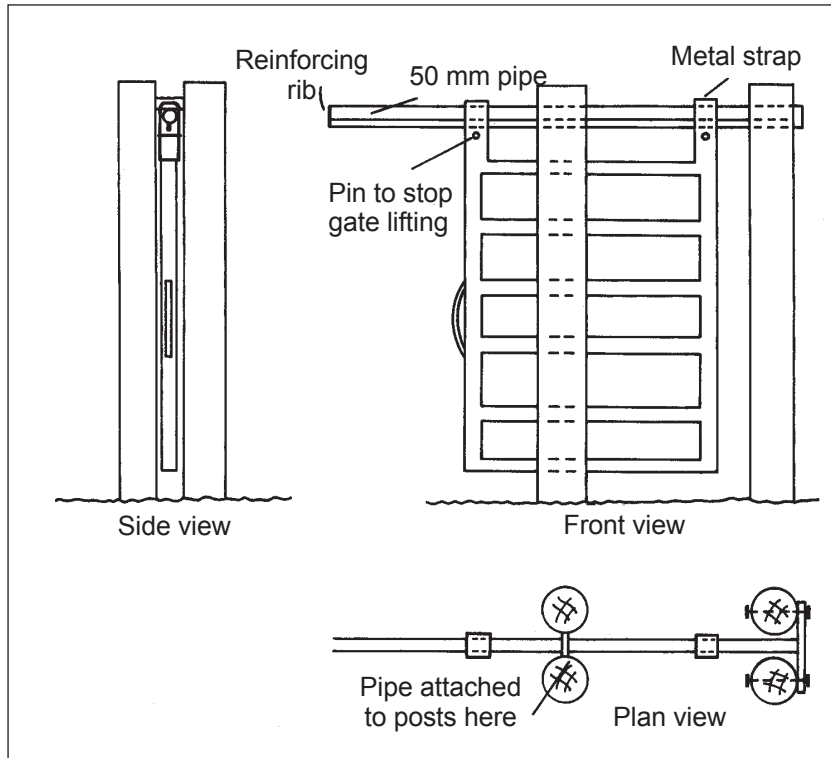

Figure 48 Slide gate on pipe running-rail

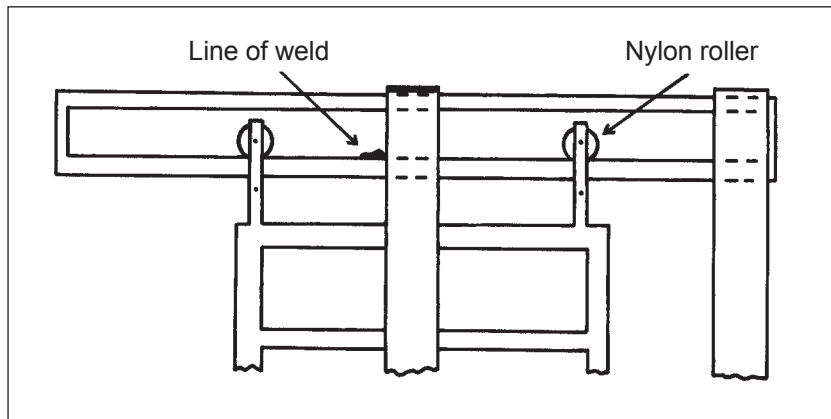

Figure 49 Slide gate on single rollers

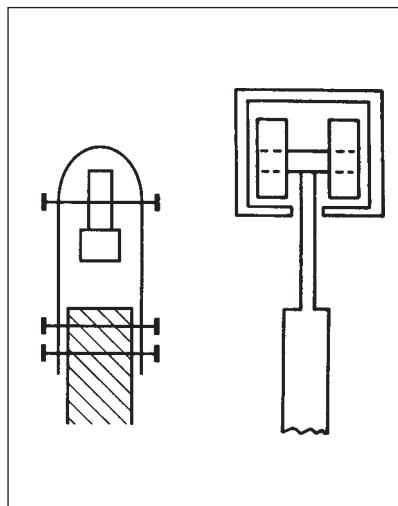

Figure 50 Single or double roller

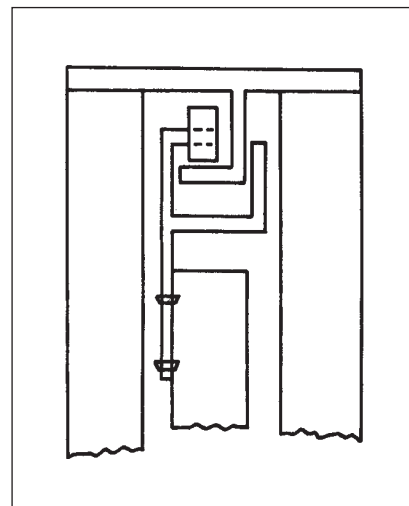

Figure 51 Angle iron running-rail

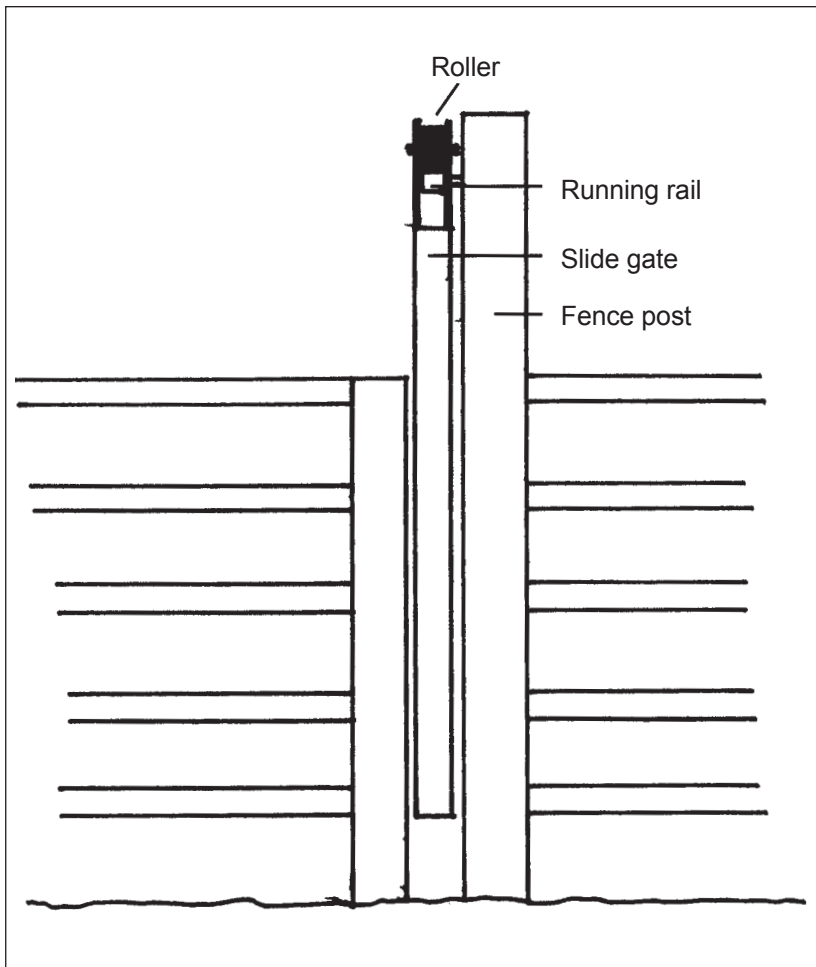

Figure 52 V-roller

Separate posts supporting the open extremity of the carry-rail are undesirable as the posts hinder free operator movement.

The slide gate bearing rail must be at least 2.2 m from the ground to prevent operator injury.

Slide gates that can be worked from both sides have a stopper on each side to prevent them sliding out of the running rail on each side.

The triangle gate (Figure 53) is an alternative block in a drafting race. It is suited to remote cable operations. The gate is a triangular-shaped structure that is let into the race side and pivoted at the front edge. The side of the triangle is slightly longer than the race width. Without a locking device it does not stop backward movement but if a forward-moving beast contacts a partly open gate it will usually block the animal and not be forced open.

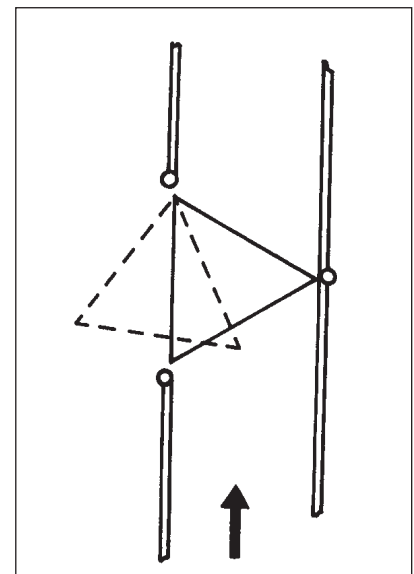

Figure 53 Triangle race gate

Veterinary crushes

The veterinary crush is a necessary facility for modern cattle management. The crush is used to restrain single animals for operations such as pregnancy testing, spaying, artificial insemination, cross branding and injury treatment. A head bail is included for ear tagging, dehorning, administering ear implants, eye treatment and other operations requiring head restraint.

The minimum requirement for herds of less than 100 head is a head bail combined with a gate on the near side of the race (Figure 54). Sufficient room (2 m) is provided in front of the bail to enable easy operator access. The gate on the near side is hinged at the head-bail end to enable operator access and drafting.

Large herds needing many veterinary operations often require a single animal waiting bay before the veterinary crush, operator access to the rear of the animal in the crush, a slide gate behind the operator, gates opening from both sides (Figure 55), and perhaps a squeeze crush.

Metal constructions are strong and enable easier operator access through the sides but excessive noise is sometimes a problem.

The same race can be used for the lead-up to the dip or, in the case of smaller yards, to the loading ramp. A rough or cleated concrete floor is recommended for regularly used crushes.

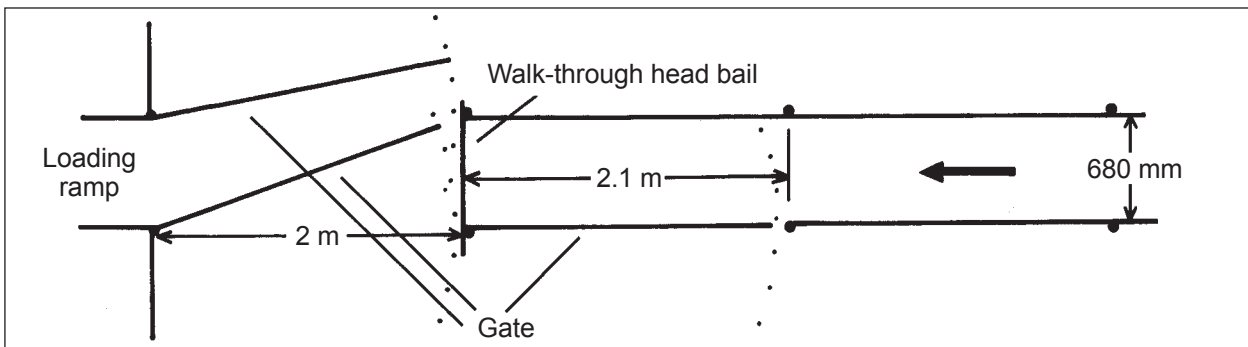

Figure 54 Small herd veterinary facility

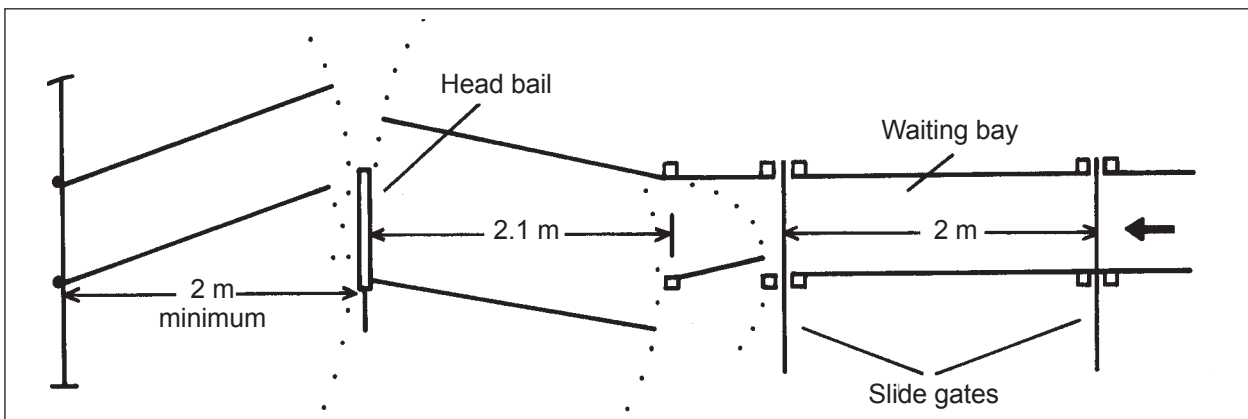

Figure 55 Large herd veterinary facility

Take care in construction to avoid any protrusions that are likely to bruise or otherwise injure animals or operators. Operating levers should not impede operator working comfort. The minimum height of caps and clearance under slide-gate runners should be 2.2 m.

A roof over the working area provides operator comfort. The roof is supported by separate posts to the race structure to reduce resounding noise. Animals often balk on entering shaded areas; this problem is reduced by starting the roof at least one panel after the forcing pen or one panel before the veterinary crush. The area under the roof should have a concrete floor to avoid bogging problems.

Crush gates need to be sturdy, swing freely and have latches that are easy to use. The gates can be constructed of 38 to 50 mm pipe or similar-sized material. Maximum space between horizontal rails should be 220 mm. To prevent animals kicking through, pipe gates should be blanked with plate steel to a height of 850 mm from the ground.

Split gates are helpful for cross branding, spaying and bull examinations. Both top and bottom halves can be opened independently but can also be used in unison (Figure 56).

The operator access gate to the rear of the animal has a minimum opening equal to the width of the race. It can be a full height gate opening outwards, or a split gate with the opening the same as the crush width, enabling the bottom gate to be used as an anti-kick gate when swung inwards and latched to the opposite side of the crush.

Figure 56
Veterinary crush - side view

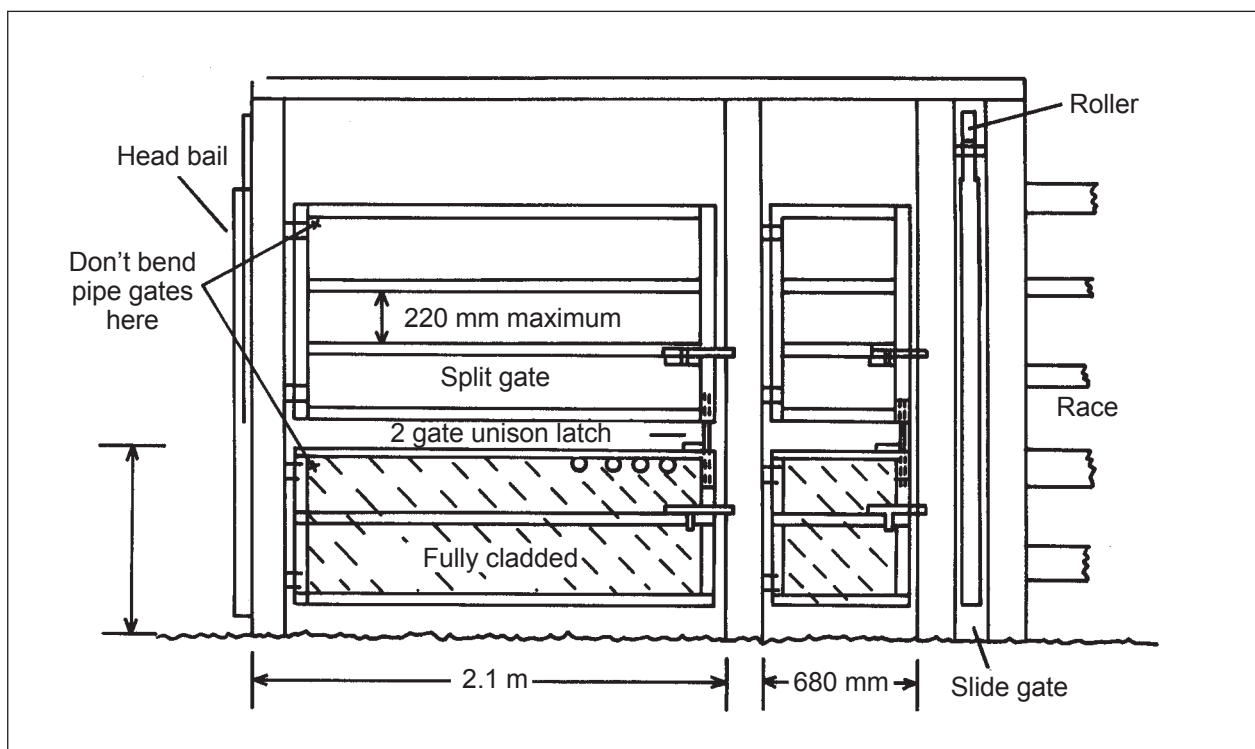

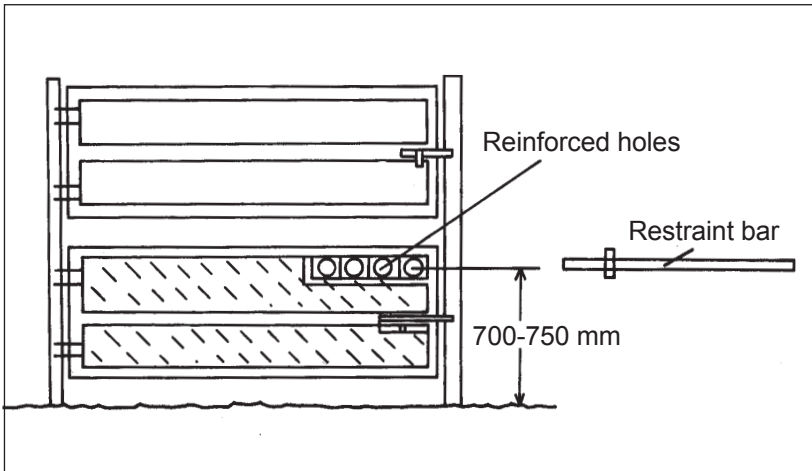

Figure 57 Variable slots for pipe

Anti-kick devices are used behind animals to prevent the operator being kicked.

The half gate shown in Figure 56 latched to the side of the race prevents the operator being kicked but does not cater for various sizes of animal. Other forms of anti-kick devices include the ratchet bar, and variable holes or slots for a pipe (Figure 57). Holes, slots and ratchets cater for different-sized animals.

Squeeze crushes cater for animals of various sizes. A squeeze crush alone is sufficient restraint for spaying but a head bail is also required for ear tagging, ear implants and dehorning. A combination of head bail and squeeze crush maximises animal restraint and reduces injury risk to the animal and operator.

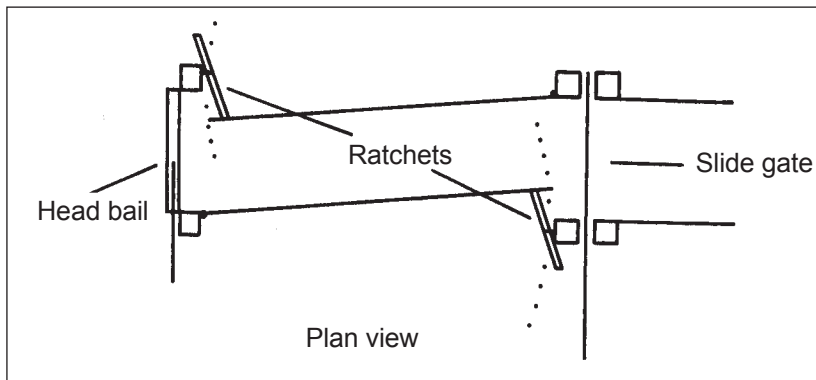

Figure 58 Squeeze gates

The squeeze gate is simple to construct and the crush gates can still be used for drafting and other normal crush operations. Figure 58 shows a plan view of squeeze gates and Figure 59 illustrates the ratchet bar used to adjust the squeeze. The ratchet bar is removed from the ratchet slot when the squeeze is not required.

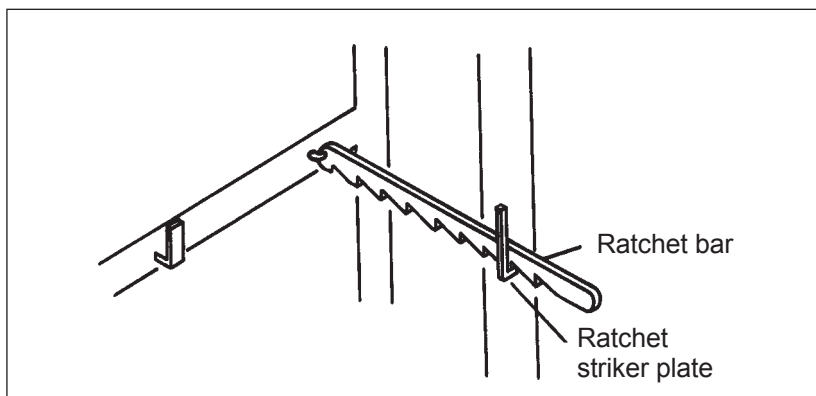

Figure 59 Squeeze gate ratchet

Several commercial crushes use a horizontal cam and lever system to squeeze or adjust crush width.

Hydraulically operated veterinary crushes and head bails may be justified for high throughputs, such as in large feedlots.

Head bails

Head bails should be capable of restraining all sizes of cattle without causing excessive stress to man or beast. A minimum of 2 m is required in front of the head bail for safe operator access to the heads of restrained animals.

Cattle readily enter the bail if the bail can open to the full crush width and there is an open view in front. This also enables adult horned animals to be bailed. In the open position, all levers should be well above the height of the tallest animal likely to be handled.

Although rear-operated bails are ideal for catching, especially in one-person situations, bails that can be operated from the front and back of the crush are better for efficient handling. Levers should be positioned so as not to impede or endanger the operator.

Head bails should be fully sheeted so that when closed they double as a crush gate (Figure 60).

Head bails with a V-yoke and guillotine-type lever are **not recommended** (Figure 61). They are not walk-through unless they are incorporated into a gate (slide or hinged), which is not convenient. Animals are encouraged to jump the blank section below the yoke. The opening is often not large enough for animals with large horns and if an animal goes down it may choke. Animals can get caught in the bail and adjustments are insufficient for small animals. Bails equipped with both guillotine and side-squeeze bars are adjusted so that the side bars hold the animals but the guillotine only stops excessive upward movement.

Walk-through yoke-type head bails (Figure 62) do not cater for optimum head-height restraint for various sizes of animals and it is possible for cattle to get caught if they go down in the bail. However, they do offer a compromise of simple operation, walk-through and height restraint. They are best used in conjunction with a 'V' crush.

Cattle will struggle excessively in a bail that chokes or that does not hold the head with the neck in line with the back. Held too low, the animal tends to go down on its knees and kick with its back feet. Held too high, the animal will attempt to rear, with the back legs going under the body (Figure 63).

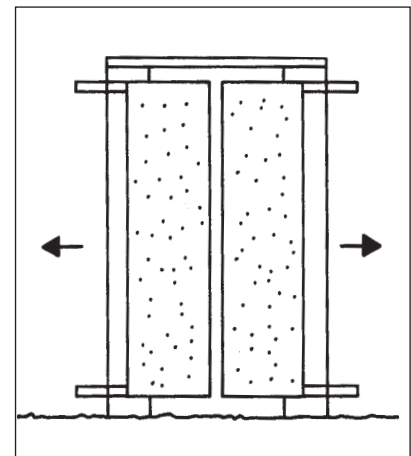

Figure 60 Cladded bail

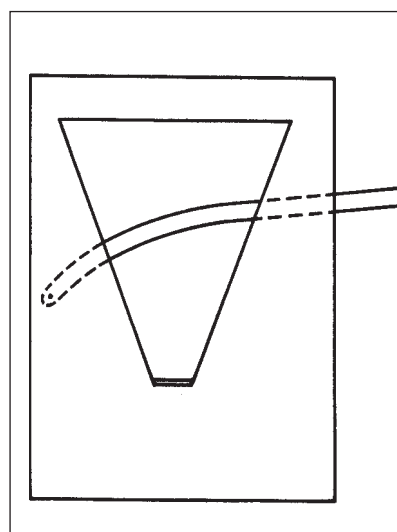

Figure 61 Guillotine head bail

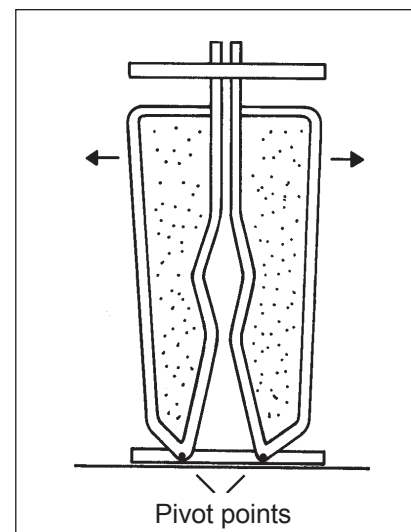

Figure 62 Walk-through yoke bail

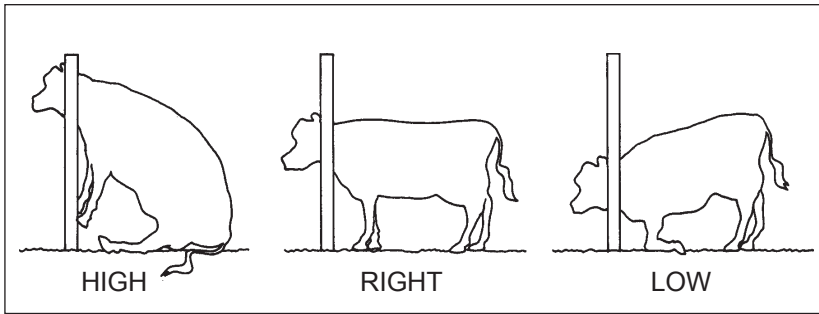

Figure 63 Head restraint height

The head bail should be able to hold all size necks without clumsy adjustment. Over centre-type head bails (Figure 64) should be fitted with a ratchet to enable all neck sizes to be restrained. Head bail levers should have a quiet, fast, positive action with a reliable catch.

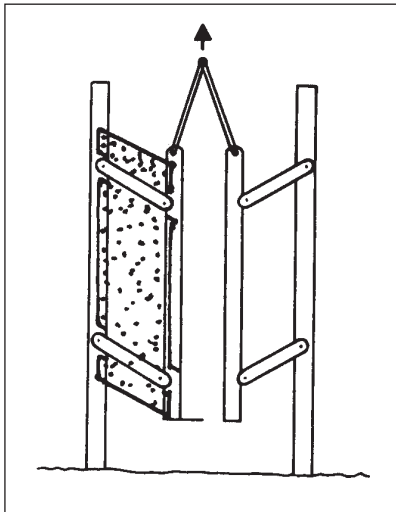

Figure 64 Overcentre bail

Excessive vertical head movement in walk-through head bails is reduced by the inclusion of a slight yoke in one or both vertical members (Figure 65); covering vertical members with trail bike tyres (Figure 66); or the addition of adjustable lugs on the verticals (Figure 67).

Head positioning lugs should be adjustable.

Traditionally, head bails were constructed similar to that shown in Figure 68. Although effective as a bail they are not walk-through and blanking is needed so that animals do not get caught or injured by the bail when it is not in use.

Head bails should be positioned for access from both sides for tasks such as tagging with NLIS devices.

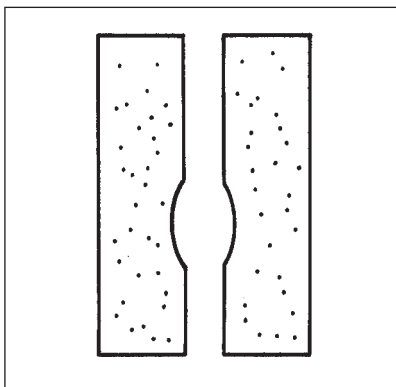

Figure 65 Head bail yoke

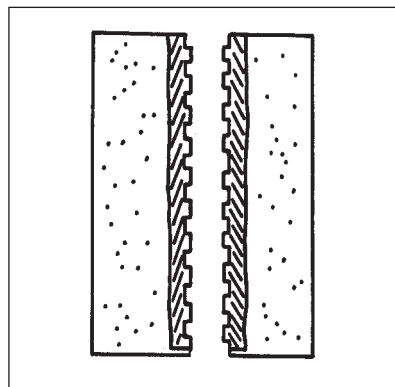

Figure 66 Trail bike tyres on head bail

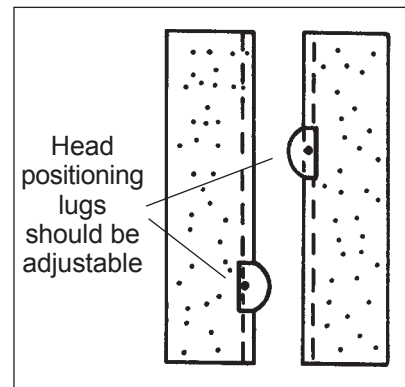

Figure 67 Head positioning lugs

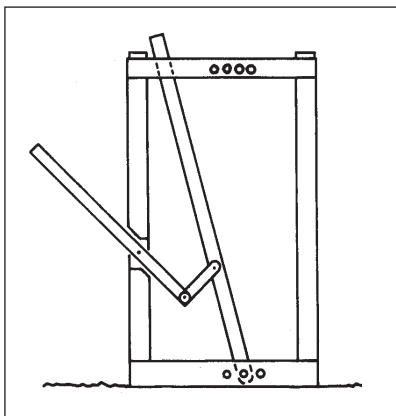

Figure 68 Sword bail

Loading ramps

A loading ramp is an essential facility in most cattle yards. The structure to be built will depend on the number of stock, frequency of loading or unloading and the animal transport employed. Construction should ensure minimum stress and bruising as this is the facility that all market stock pass through.

The ramp is sited to enable all-weather access if possible and provide adequate manoeuvring space for the largest vehicle likely to be used. Larger properties need to consider side loading. The ramp protrudes from the yards to enable side loading and reduce the risk of damage to vehicle and yards.

A loading ramp at the end of the main race reduces expansion possibilities for the yards and may reduce loading efficiency. However, on holdings with fewer than 200 head and no dip or other facility in front of the main race, this is the most cost-efficient position.

Larger holdings should consider a separate forcing pen of 'half-deck' capacity. A double forcing pen (Figure 37) is a further alternative provided vehicle access is not impeded.

The requirements for loading and unloading vary. In high-volume situations a separate unloading ramp can be constructed alongside the loading ramp. Separate unloading ramps should provide unrestricted stock vision, that is, open panel construction and have a minimum width of 1.5 m, to a maximum of 3.0 m preferably at truck deck height with a level section at the top of at least 1.5 m to 3.0 m. This ramp is also suitable for horses (Figure 69).

Where semi-trailers are mostly used to transport stock, the recommended loading ramp height is 1.17 to 1.2 m. However, some small farm trucks may require a slightly higher ramp. The internal width of the ramp should be 760 mm.

A 1.17 m high ramp about 3.5 m long gives a maximum slope of 1 in 3 (30°). Steeper slopes (30° or greater) are likely to cause stock baulking and slipping during loading and unloading. Gentler slopes of 1 in 4 or 5 (20°) are better and are recommended for loading and unloading (Figure 70).

Cattle tend to load best if the sides of the ramp are fully cladded. This modification is suggested for any traditionally open-sided ramp where loading difficulty occurs. Sides are enclosed with 25 mm minimum thickness hardwood planks, or similar strength heavy-duty ply, plate steel or rubber belting. The space between open rails is no more than 250 mm.

A panel's length of race at ground level before the start of the incline encourages cattle to draw more freely on to the ramp.

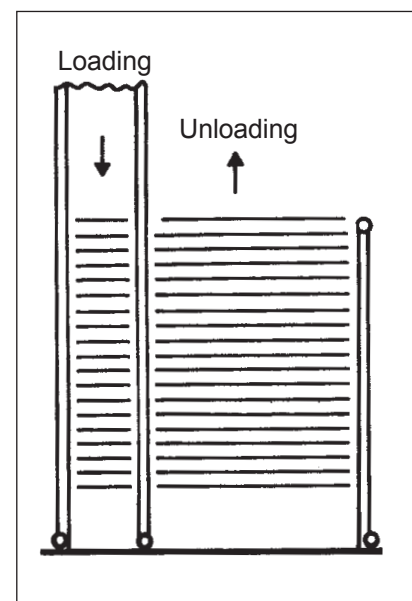

Figure 69
Unloading and loading ramp

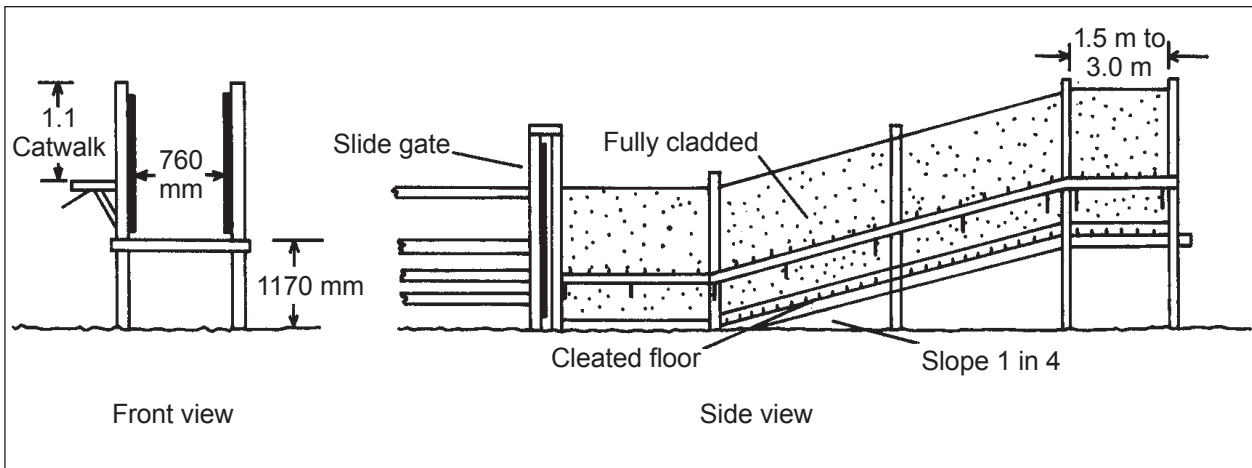

Figure 70
High-volume loading ramp

Stock often load best in a curved ramp with fully clad sides (Figure 71) where they cannot see the truck. The radius of the inside curve should be 5 m. Tighter curves impede loading and unloading efficiency.

Alternatively, a ramp angled 15° off the lead-up race of the forcing pen also helps loading (Figure 72). Fully clad curved or angled ramps may tend to slightly increase unloading time.

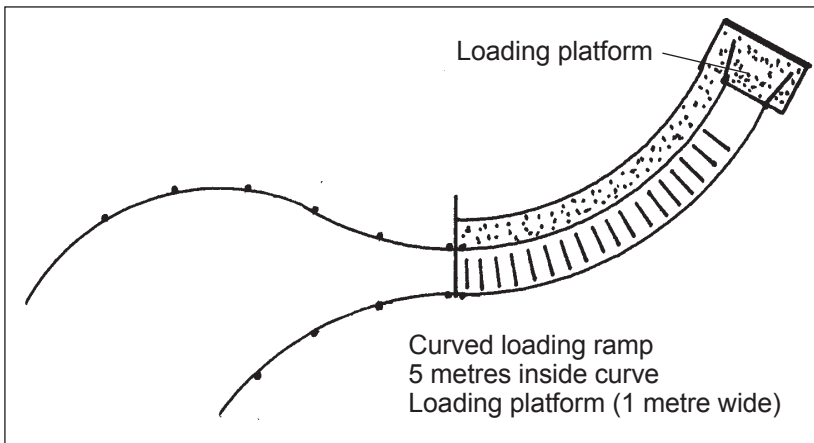

Figure 71 Curved loading ramp

Although cattle load well with an earth floor this is often impractical as earth is extremely difficult to stabilise and needs frequent maintenance. If earth is used it should be enclosed with 150 mm reinforced concrete or railway sleepers.

Concrete makes a good ramp floor provided it is poured in steps or that cleats are constructed in the concrete. Cattle work well on steps with a 400 to 500 mm tread and 100 mm rise (Figure 73).

Timber floors made of 100 x 50 mm hardwood are another alternative. Creating cleats by standing every third board on edge prevents cattle slipping (Figure 74).

The ramp floor should extend at least 600 mm past the sides of the loading ramp

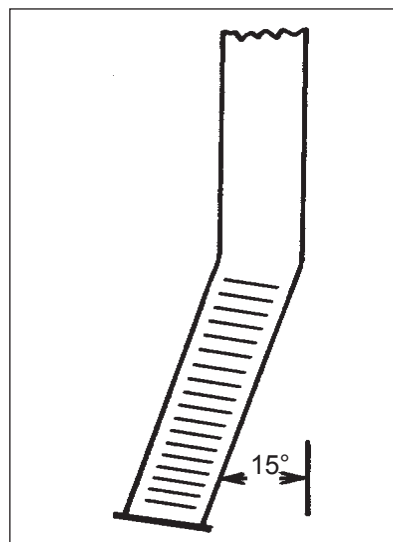

Figure 72 Offset ramp

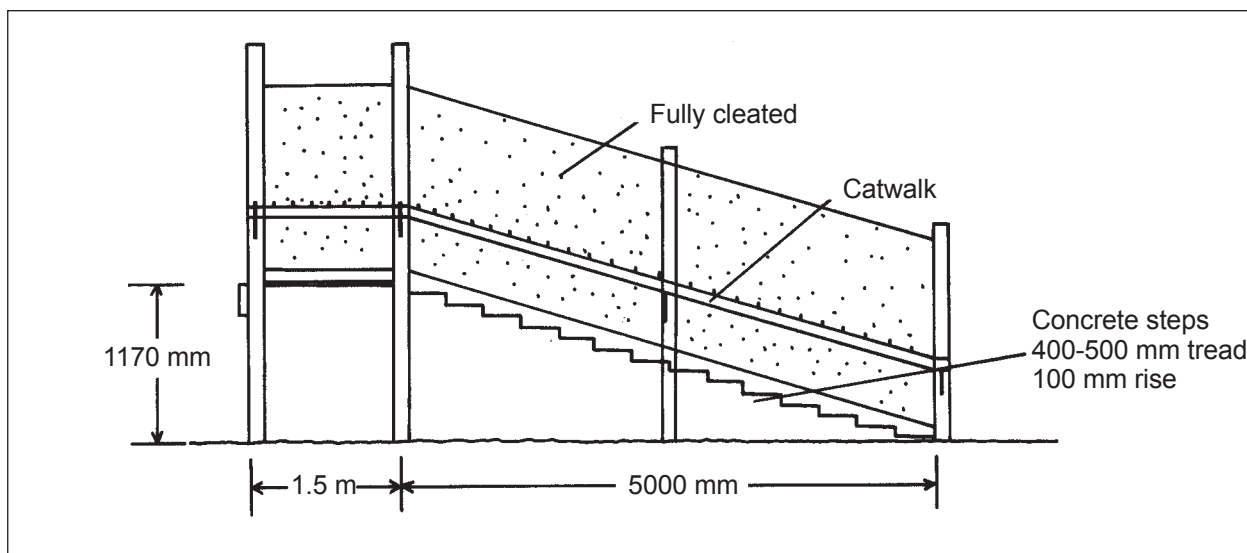

Figure 73 Stepped loading ramps

to prevent animals getting their feet caught between the bottom rail and the race floor.

A race gate is provided at the ground entrance so that cattle can be held awaiting loading.

Other aids to loading include a catwalk (minimum width 500 mm) along one or both sides of the ramp and a manway to the forcing pen.

Self-aligning buffers help reduce injuries caused through poor truck alignment with the ramp. However these buffers rarely withstand continuous loading pressures.

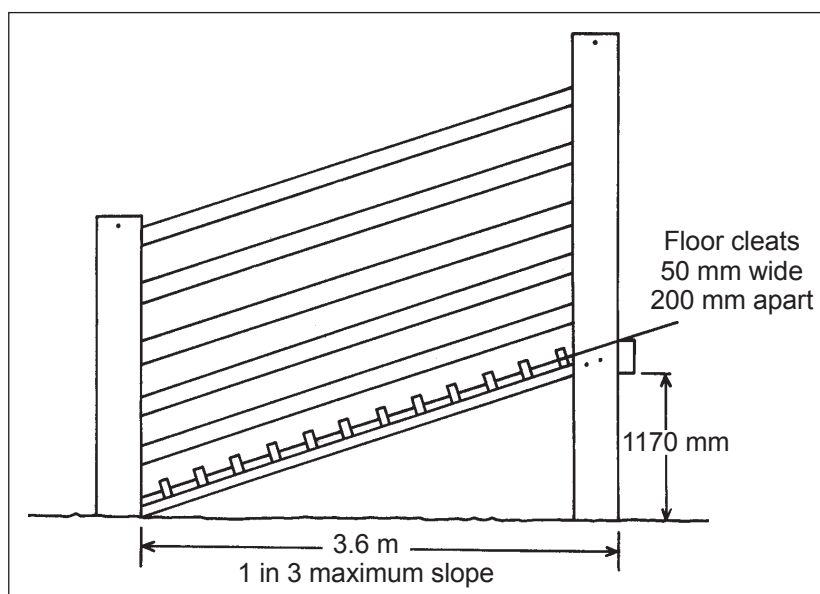

Figure 74 Cleated ramp floor

Double-deck ramps

Double-deck loading ramps (DDLR) save time loading/unloading, reduce bruising and are less stressful to stock. Fixed DDLR are preferred. However where only small numbers of cattle are loaded each year, adjustable DDLR could be considered as they are cheaper to construct. Wing gates are important for DDLR as they compensate for minor truck alignment errors. Plans for double-deck ramps are available on request from the Department of Primary Industries and Fisheries, Queensland.

Calf races

A separate calf race and branding cradle is justified on any breeding property branding more than 50 calves at one time. The calf race can be located off the main forcing pen by making use of the third corner or by using a dual-purpose forcing pen (Figure 37). A separate calf-forcing pen is more convenient with large numbers.

The side of branding will influence where the calf race is located. If a plan provides for nearside branding, and off side branding is required, a mirror image of the plan can change the branding side. The calf race can be constructed along a fence line to reduce building costs but should not be built alongside the main race as this impairs handling efficiency. Figure 75 shows the plan view of a calf race and waiting bay.

The race is 5 to 7 m long in panels of 2 to 2.5 m. A dividing gate is provided in longer races to reduce bunching, possible smothering or injury. The race sides should be 1150 mm in height with fully enclosed sides to a minimum height of 900 mm.

Internal width of a calf race should be 400-600 mm. Calves' legs are often caught in open-sided races.

A 1.5 m long waiting bay in the race at the entrance to the cradle helps handling efficiency.

A 100 mm wide rail centrally located over the full length of the race and waiting bay will prevent calves climbing out. The rail is held in place by a metal bracket to enable easy removal if it becomes necessary to rescue calves (Figure 76).

A self-latching gate should be situated at the race entrance and exit. The exit gate rests on the standing cradle when open but opens further when the cradle is tipped. This positioning of the gate and cradle prevents calves escaping between them.

There are two basic types of calf cradle, one that restrains the calf on the ground and the second 'spin-roll type' that holds the calf off the ground. The former is better for restraining large calves. The latter reduces the chance of infection, saves the operator bending over as much, and holds the calf better in the standing position but leg restraint is not as good for large calves requiring castration.

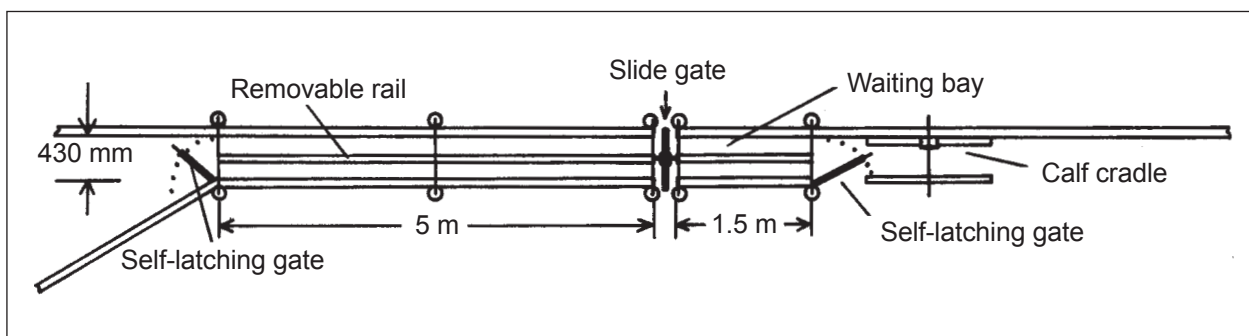

Figure 75 Calf race

Whichever is used, the cradle is mounted on a concrete block or a bed-log base. Ground-level cradles should stand vertically against the fence, otherwise throwing or tipping is more difficult. Concrete platforms should not extend past the front of ground-level cradles so that calves do not hit their heads when thrown. A car tyre or small truck tyre is placed on the concrete to break the fall of the cradle and calf. The tyre is worked into the wet concrete so that there is a groove to keep it in the correct position.

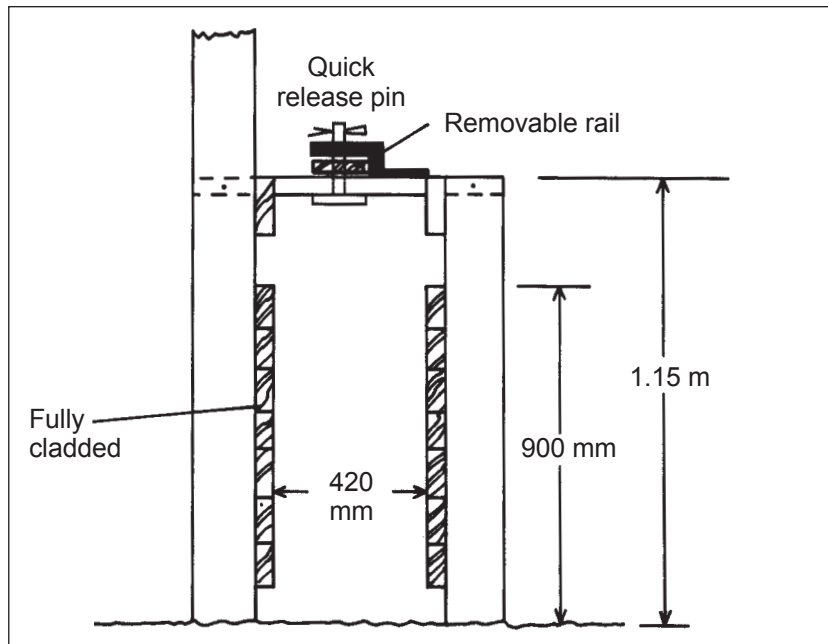

Figure 76 End view of calf race

A baulk in front of the cradle steadies the entrance of calves. The cradle should be in shade for the comfort of animals and operators.

Where calf numbers are insufficient to warrant a calf race they can be manually scruffed. Alternatively, removable panels are placed in the main race (Figure 77) to enable efficient calf handling by narrowing the adult race width.

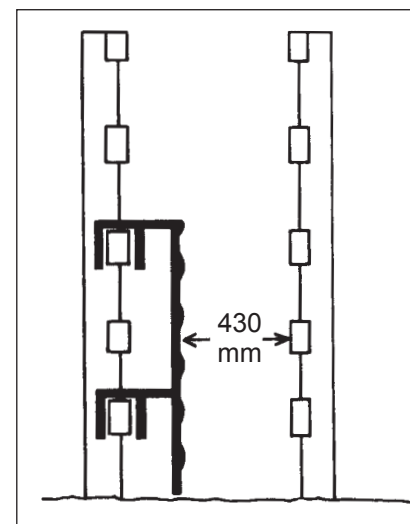

Figure 77 Removable calf panels

Where there are fewer than 50 calves to be branded at one time a simple flank bar (Figure 78) in conjunction with a head bail can be used to restrain calves. Alternatively, calves can be thrown bronco-style by leg-roping one front and one back leg on the same side and pulling on the ropes until it falls. The ends of the leg ropes are tied to posts and a stockman holds the calf's head. Calves can also be thrown and restrained by one person on the head and one on the hind legs. This operation requires at least three people.

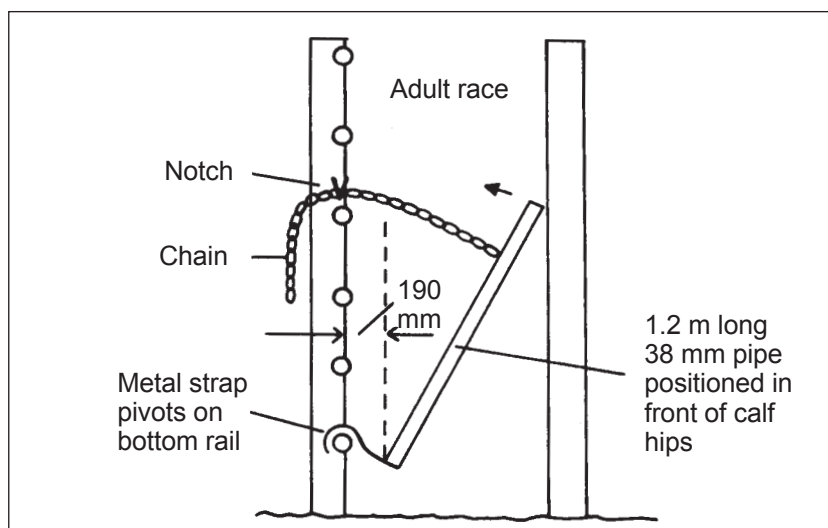

Figure 78 Flank bar

Plunge dips

Cattle ticks are present throughout much Queensland. Despite the increasing use of alternative chemical products, such as pour-ons and vaccines, there is a continuing role for plunge dips.

Properly maintained plunge dips remain an efficient method of treating large numbers of cattle.

This book does not cover the finer points of dip design and management, only the basic considerations for inclusion in a total yard plan. Detailed designs for dips, are available from local stock inspectors.

Dips are best located on firm but porous ground with a slight slope for drainage from the draining pen or race. Avoid very heavy clays, sands and rocky areas. A water supply is required for charging, topping up and cleaning.

When cleaning, care should be taken to ensure that any dip or cleaning fluid cannot pollute any nearby water courses. The dip vat should be constructed before erecting surrounding yards.

The lead-up race to the dip should be no wider than 760 mm and have a minimum length of 8 m before the foot bath or grid. Races of this length and longer encourage a steady flow of stock through the dip with less labour required. The race floor is concreted to reduce dip pollution. Because of the length of lead-up required the dip is usually sited at the end of the main race. A slide gate is located as a block gate at the dip approach.

Pollution is a major problem in dips. Dung, urine and dirt build-up in the dip reduces the effectiveness and life of the wash. More frequent and costly topping-up and recharging is therefore necessary.

A foot bath or grid mesh or both are incorporated in the race to clean hooves before stock enter the dip. The foot bath is at least 3 m long and 200 mm deep with a corrugated bottom. The grid mesh is made of expanded metal 2.2 to 2.4 m long and has proved to be as effective as a foot bath. Provide a minimum clearance of 150 mm under the grid to assist in cleaning.

A concrete block 300 mm high immediately following the grid or foot bath encourages stock to lift their feet, leaving dirt behind.

The remaining section of the race to the dip has cleats 60 mm wide, 40 mm high and 250 mm apart to further reduce dirt being dragged in, as well as providing a non-slip footing. This dip approach is level and 1.4 to 2 m long.

A crowding gate immediately before the dip helps assure single-file entrance with young cattle (Figure 79).

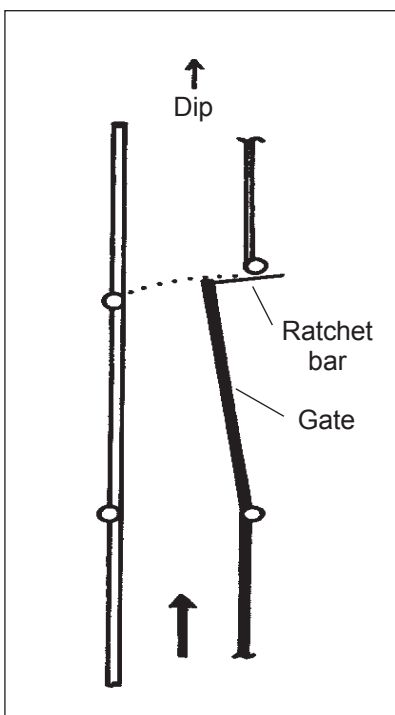

Figure 79 Dip crowding gate

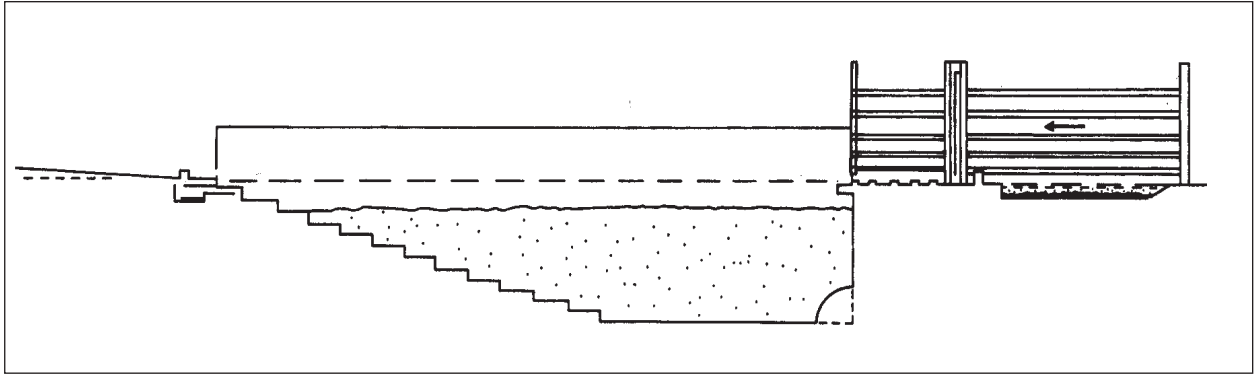

Figure 80 Side view of dip vat

Reinforced concrete is usually the material of choice for plunge dip construction. Concrete blocks, fibreglass and steel constructions are also used.

The vat has a total length of 11.5 m, is approximately 610 mm wide at the base and 1050 mm at the top. The exit ramp is staired with a slope of 20°. A 150 mm ledge at the top of the ramp ensures wash returns via the sump. Splash walls are 1 m high. A side view of dip layout is illustrated in Figure 80.

A roof over the vat prevents rain diluting the wash, reduces evaporation and protects the wash from breakdown by the sun. Shade trees should not be situated too close to the dip as leaves pollute the wash and roots may damage the vat.

Single draining pens 20 to 25 m² in area are suitable for small herds. Speed of operation is increased with a double draining pen as dipping can continue while one group is draining. Allow an area of 1.2 m² per head.

Draining races are sometimes preferred to pens. Stock do not become so agitated so there is less dung and urine returned to the dip or spray sump. Slightly more wash is lost but this is compensated for by saved time and longer dip-life.

Light, open construction material can be used in the draining race as there is low stock pressure but a fence with a good visual barrier will assist stock flow. The slope of the concrete floor is sufficient to ensure wash returns to the vat. The race is curved to steady stock speed. Minimum race length is 17 m but 20 m is better, with an internal width of 760 mm. A plan view of a dip layout and draining race is illustrated in Figure 81.

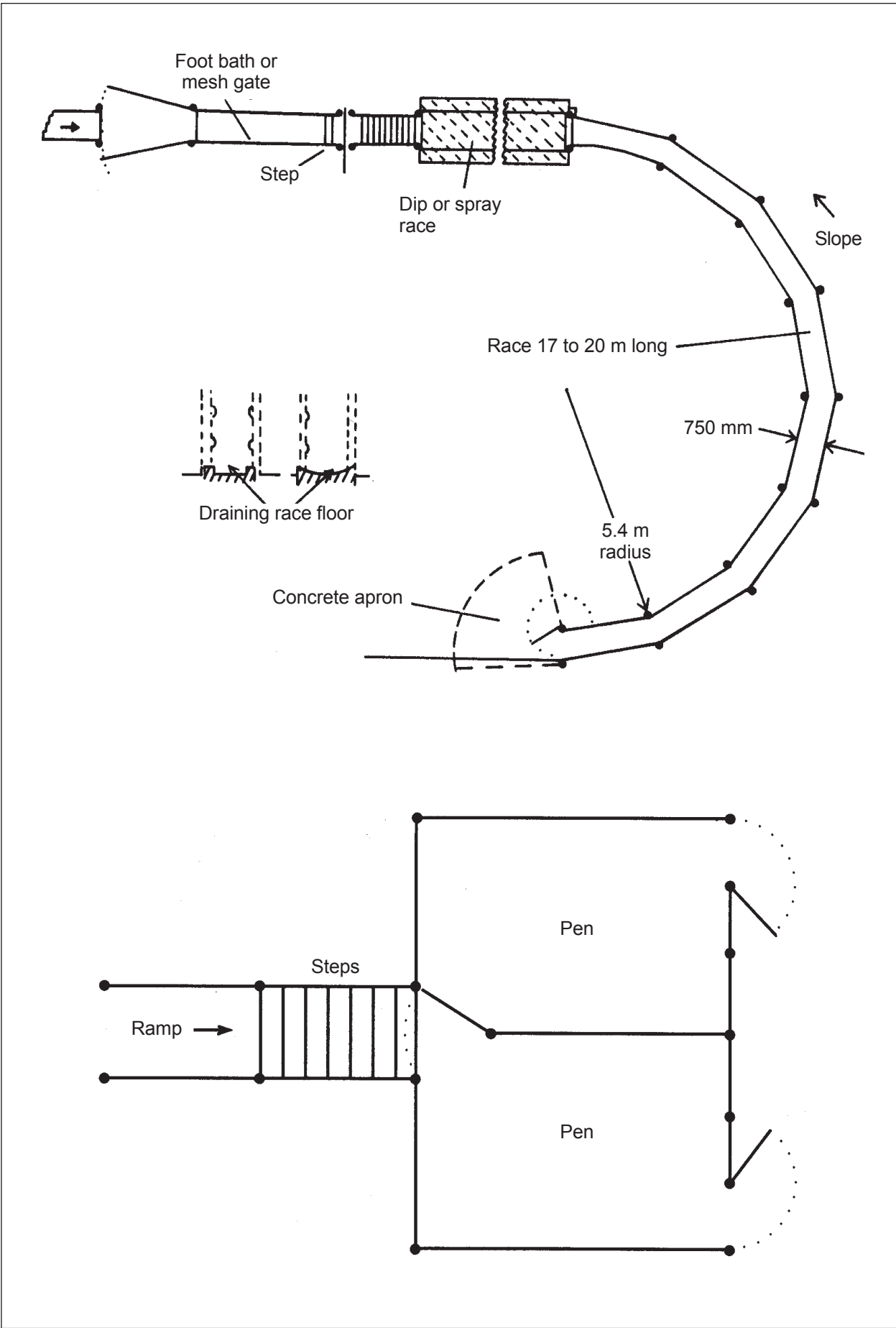

Figure 81 Draining race and draining pens

Cattle scales

There is an increasing demand for on-farm cattle scales in breeding selection programs and for efficient marketing of livestock. Provided scales weigh consistently, that is, so long as the error is constant, they are suitable for breeding selection. Scales used for marketing decisions must be accurate.

Scales are best sited in the yards so that only stock to be weighed pass over the scales. This can necessitate a separate race or a removable scale platform. Alternatively, scales can be offset from the main race or placed under the veterinary crush.

Knife-edge mounted scales

These are heavy, precision-built, and accurate. The weight is registered through a system of levers linked to a graduated beam, clockface or digital readout. Scales with a beam or steelyard are more accurate than those with a clockface but are slower to operate. Most of these machines have the accuracy required to comply with the National Standards Commission requirements for trade. The error rating of common models is 0.05%.

Electronic scales

With the use of load cells (strain gauges) the weight can be displayed on solid-state digital readouts or stored in electronic memory for later processing and sorting.

Electronic scales do not have to be exactly level for accurate recording, and are usually operated using a battery power supply. Electronic scales are often used under a veterinary crush or weigh crate. Weighing platforms placed under the bottom rail of a yard race are suited to quiet cattle only. In this situation the operator must ensure that stock do not touch any part of the race if accurate weights are to be recorded. Cattle will generally stand quietly in a fully sheeted weigh crate and this greatly increases the scale efficiency and accuracy.

More recently, scales are placed in the panel preceding the vet crush and load cells can be removed when not required. The platform can be secured directly to the floor.

Expanded metal floors are not recommended as dirt and other material build up under the floor. This build-up prevents accurate weighing and when wet will corrode load cell connections, rendering the scale useless. Modern electronic scales can now 'lock onto' a weight which eliminates operator error. They can automatically 'tare off' or zero to compensate for any build-up of dirt or dung on the platform to ensure accurate weights.

It is essential to bolt the veterinary crush or weigh crate to the load cells or load beams. The load cells should then be secured to the ground to prevent the crush or crate from moving and contacting the other structures to give incorrect weight.

Weigh crates are generally 1800 to 2000 mm high, 2500 mm long, and 760 mm wide. Another version is 380 mm wide at the base tapering out to 800 mm wide at 900 mm high. It then remains at 800 mm wide to a height of 1800 or 2000 mm (all measurements are internal). Weigh crates are normally fully sheeted to encourage the animals to stand quietly. An opening near the head of the animal is recommended to allow ear tags to be read.

Other important features to look for are:

- easy-to-read digital display with enough characters to suit your needs
- adequate memory storage for your needs
- downloading compatibility with your own home-based computer system
- fast reliable back-up (repair) service available.

Electronic scales now mostly include software programs that will sort animals into a weight or tag order. These can be useful but may not always suit particular property requirements.

NOTE: Read and follow the manufacturer's instructions before installing the scales and make sure that the battery is connected properly.

Some properties now have a bench for a laptop computer. The computer is within an enclosed shelter to reduce dust and glare on the screen. The laptop can be connected directly to the scales, NLIS wand and even gate operating software systems.

Consideration should be given to cabling, power, shade and protection if IT systems are to be incorporated into a yards design.

Artificial breeding facilities

Successful artificial breeding or artificial insemination (AI) requires cows to be restrained in a shaded area while keeping excitement, stress and dust to a minimum.

Provide a roof over the area where the semen is prepared and over the cow being inseminated. A concrete floor reduces dust problems. Clean water is required for hygienic operation and noise must be kept to a minimum.

Quiet cattle accustomed to the handling facility require nothing more than to stand in the crush without being restrained by a head bail. Cattle worked in strange surroundings such as in portable yards become more excited, resulting in lower conception rates. A previous association with the veterinary crush for more painful operations may also excite cows.

It is necessary to have a bail or gate that stock will not attempt to get through when held in the crush. Waiting stock are held quietly in a blank-sided race. A britchen device is used to prevent the inseminator from being kicked. A car tyre placed inside the crush (Figure 82) makes it easier to keep the cow off the crush wall.

Excited cattle can be settled by having a pacifier cow stand in front of the cow being inseminated (Figure 83). The pacifier is a quiet non-heat animal.

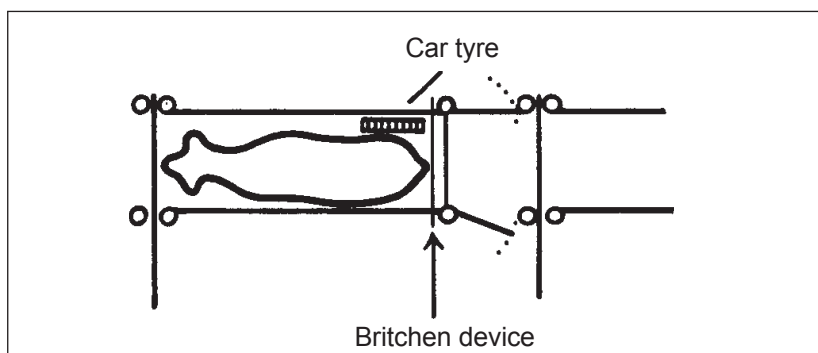

Figure 82 An AI facility

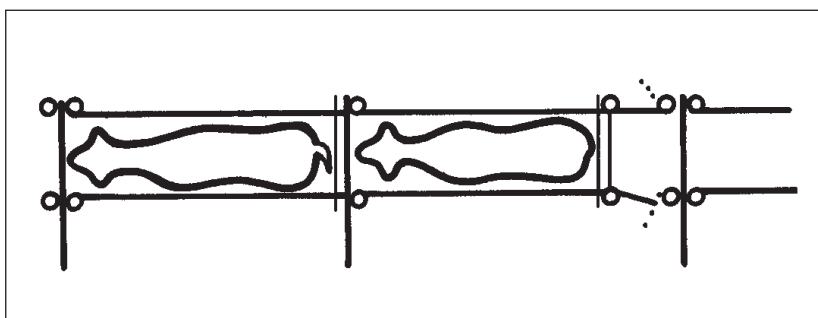

Figure 83 A pacifier cow for AI programmes

Portable yards

Portable cattle yards should be considered if there is excessive droving distance to central yards and the cost of further permanent facilities is prohibitive.

Extensive properties can have strategically located permanent holding paddocks, or trap yards, to which portable yards are attached when that part of the property is being mustered. Alternatively, portable yards can be placed in areas where problem cattle do not expect them.

Portable yards can be used successfully on grain-growing properties in association with temporary fenced paddocks or in other areas when cattle are infrequently run. Hobby farmers may prefer to invest in a moveable asset, especially when the future of the farm is in doubt.

The cost and convenience of portable facilities should be weighed against those of permanent yards. Taxation aspects should also be considered, as moveable assets can be depreciated at a higher rate than permanent improvements.

Many commercial firms manufacture a range of portable cattle-handling facilities, including yard panels, veterinary crushes, calf races, branding cradles, race frames or bows, gates, loading ramps, and drafting pounds and races.

Unlike permanent yards, the layout of portable yards can be changed if stock are not working well in the initial plan.

Portable panels should be of light but robust construction with simple, strong, connecting devices that resist bending, make erection and dismantling easy, and allow for ground undulations. Most panels are openly constructed and provide little visual barrier to stock. Visual blanking of some panels often assists cattle flow. Most panels are made of box section steel in preference to pipe as it is easier to cut out and weld strongly and is less likely to bend.

Portable panels that are pegged in position are usually less stock-proof and are more likely to be damaged by cattle. The use of portable panel trailers, commonly called 'coat hangers' increases the ease of dismantling, moving from site to site, and erection.

A typical panel consists of six rails 2.1 to 2.5 m long and 1.5 to 1.8 m high.

Yard plans

This chapter illustrates yard plans to suit different-sized herds. The plans are drawn to scale but the text should be consulted for dimensions before building specific features such as races, loading ramp and pounds. Where a yard needs a circular or semi-circular perimeter, the plan shows the arc centre around which the perimeter can be marked.

The receival capacities shown allow for one adult beast for every 2.2 to 2.3 m². These yards may hold up to 10% more cattle without affecting working efficiency.

The plans show individual panels. Various fence construction methods and building materials are discussed in the text but are not shown on the plans.

PLAN 1

A hobby farmer's yard designed to receive 20 head. It requires a small paddock to assist receival and retain accidental escapes from the race.

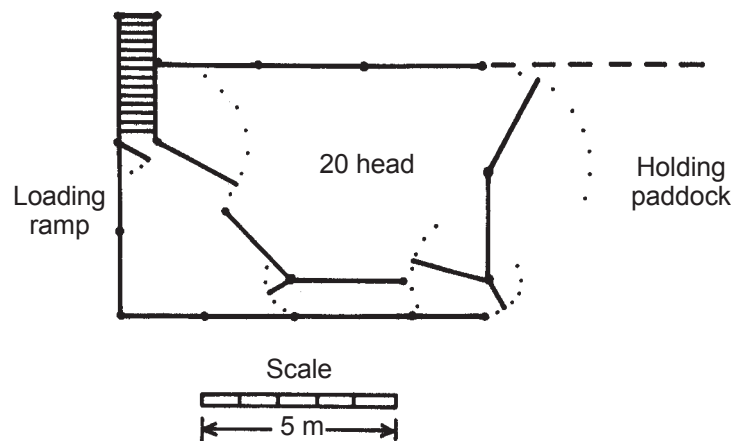

PLAN 2

This yard will receive 20 head and has better access to the head bail area than plan 1. With very limited drafting capability it requires a small holding paddock to assist receival. An additional holding yard can be erected on the offside of the race.

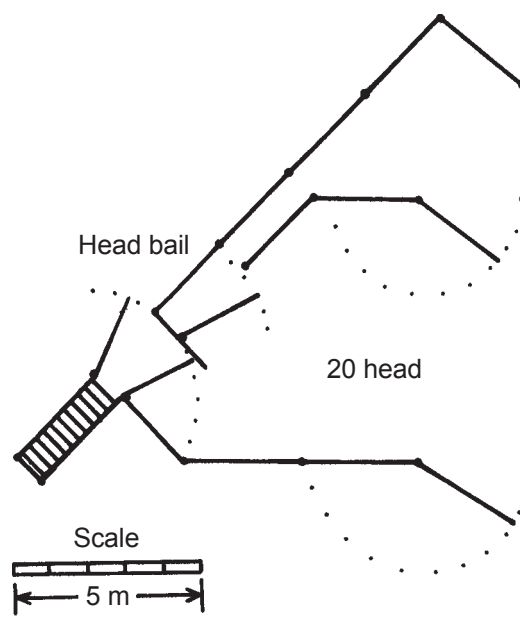

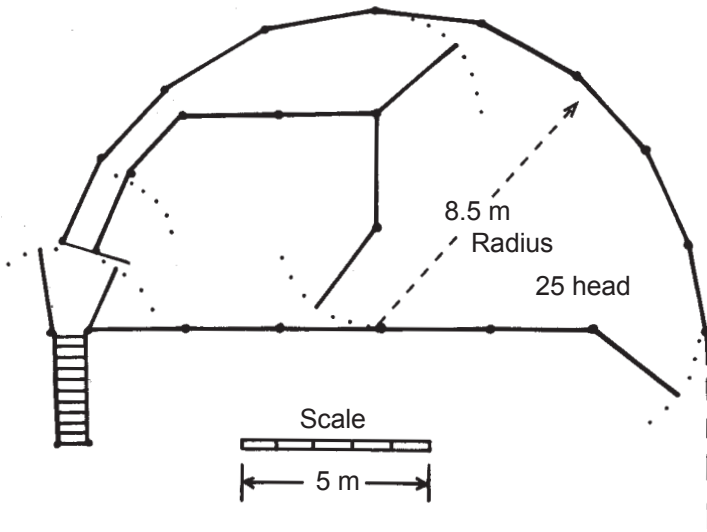

PLAN 3

This yard has a greater drafting capacity than those in plan 1 and 2. Worked stock can be retained. Cattle work well around the curve.

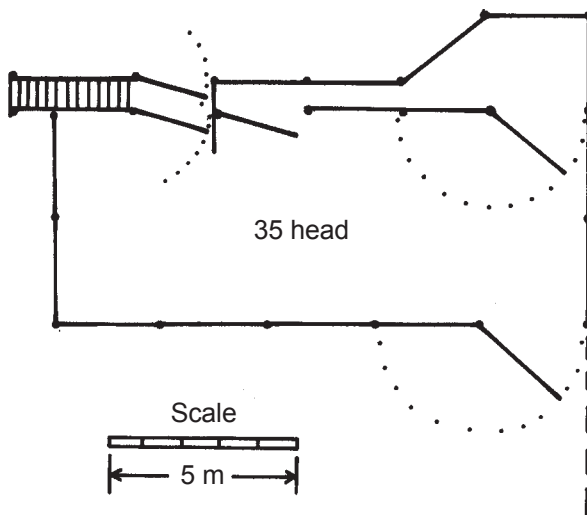

PLAN 4

Worked cattle cannot be retained in this yard. Stock may resist being moved into a shallow forcing pen. Additional holding yards can be erected on the offside of the race or at the back of the forcing pen.

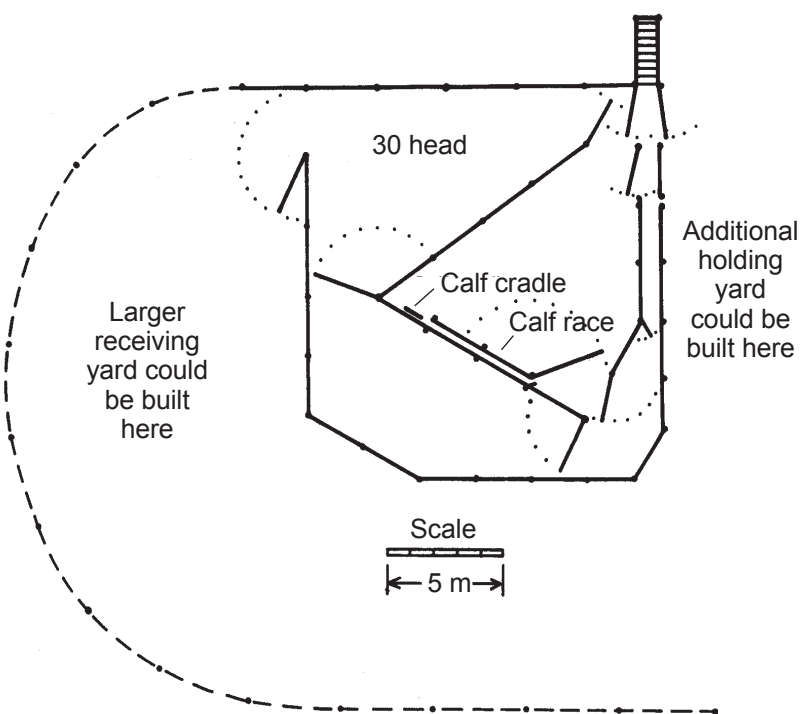

PLAN 5

This plan can be expanded with a larger receive area on the left-hand side and extra holding area on the offside of the race. The wing enables stock to be received on the opposite side of the yard from the initial approach. This encourages stock to work through the yards. Race drafting two or three ways is possible.

PLAN 6

This yard will receive 60 head but if the holding pen is included it will receive only 40 head. It offers limited drafting alternatives but can be easily expanded.

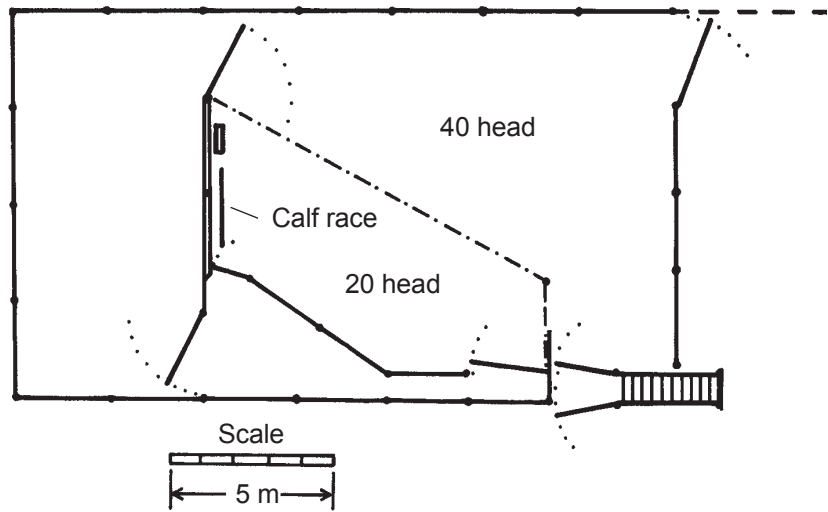

PLAN 7

This yard can be built in stages while still providing some working facility. The small pound is suited for drafting into only. Drafting alternatives are adequate for 100 head receipt. The calf race can be moved to opposite side of same yard for offside branding.

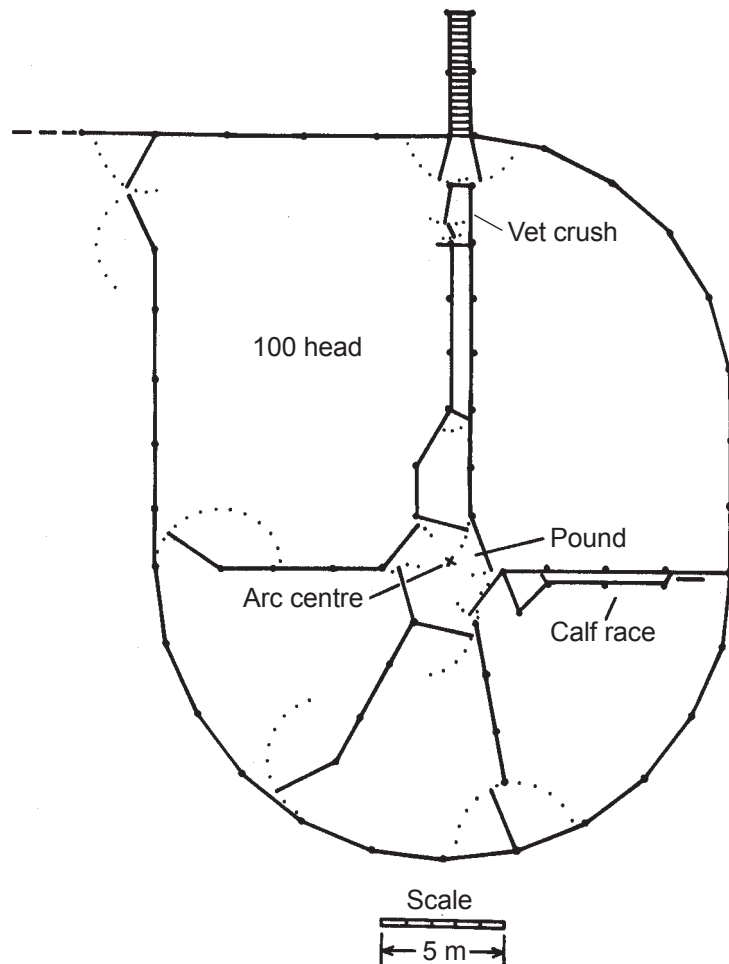

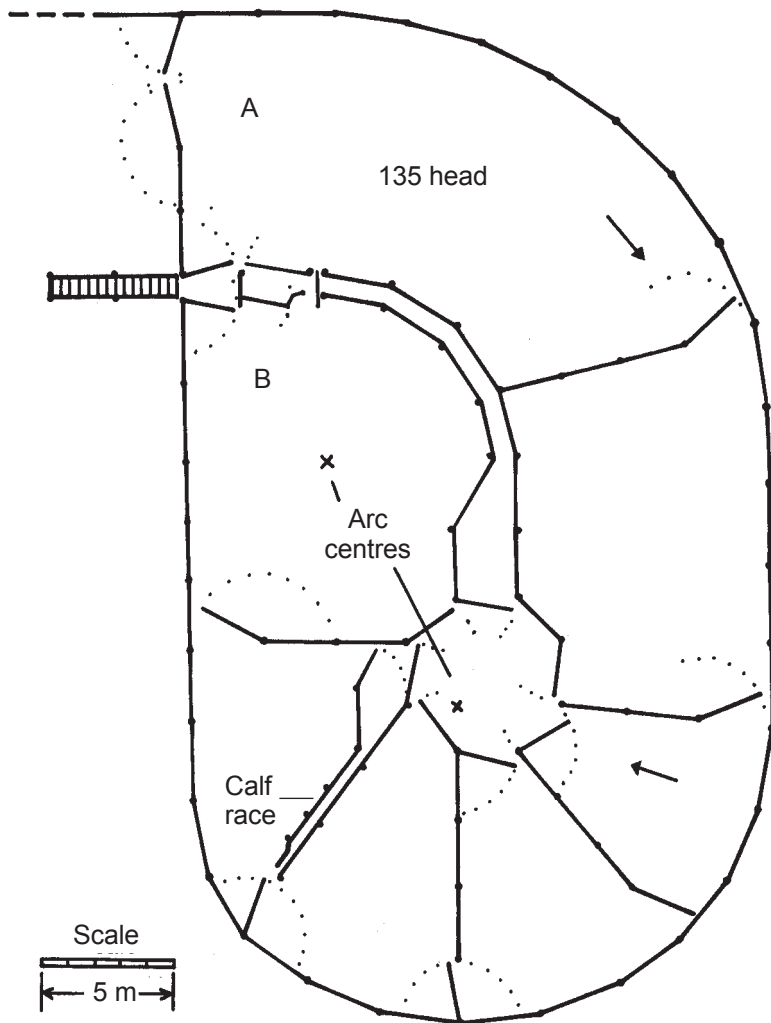

PLAN 8A

This plan is ideally suited to working mobs of 100 to 200 head. It has been adapted from the 'Weean' plan originally reported by I. Dixon of the New South Wales Department of Agriculture. Relocation of the loading ramp to the calf race fence and extension of yards 'A' and 'B' enables a dip to be incorporated into the plan.

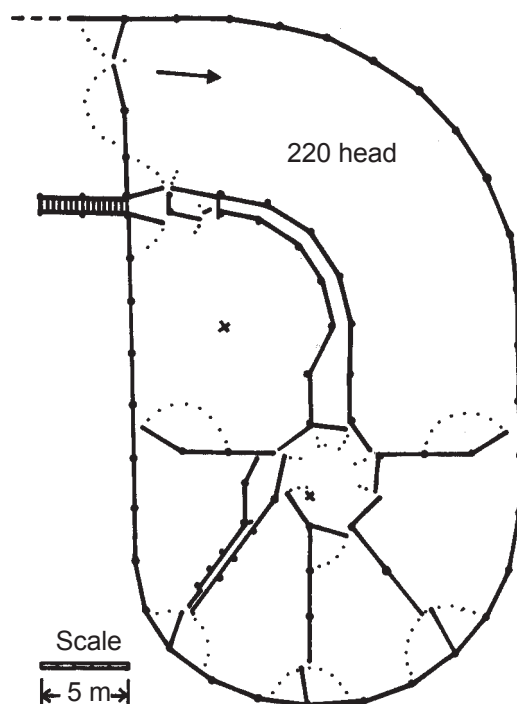

PLAN 8B

This modification to the receiving yard increases initial receive capacity but does not provide sufficient post working holding area.

PLAN 9

The total capacity of this yard is in excess of 300 head but the receival yard will hold only 120 head. A small holding paddock at 'A' would greatly increase yard capacity. The dip lead-up race should be at least one panel longer. It has a good forcing and drafting yard. A separate veterinary race is not necessary with a longer dip lead-up race. Right angle corners in the pound reduce handling efficiency. It is difficult to work cattle in forcing pens with acute angles corners. This yard has two-way race drafting option plus pound drafting.

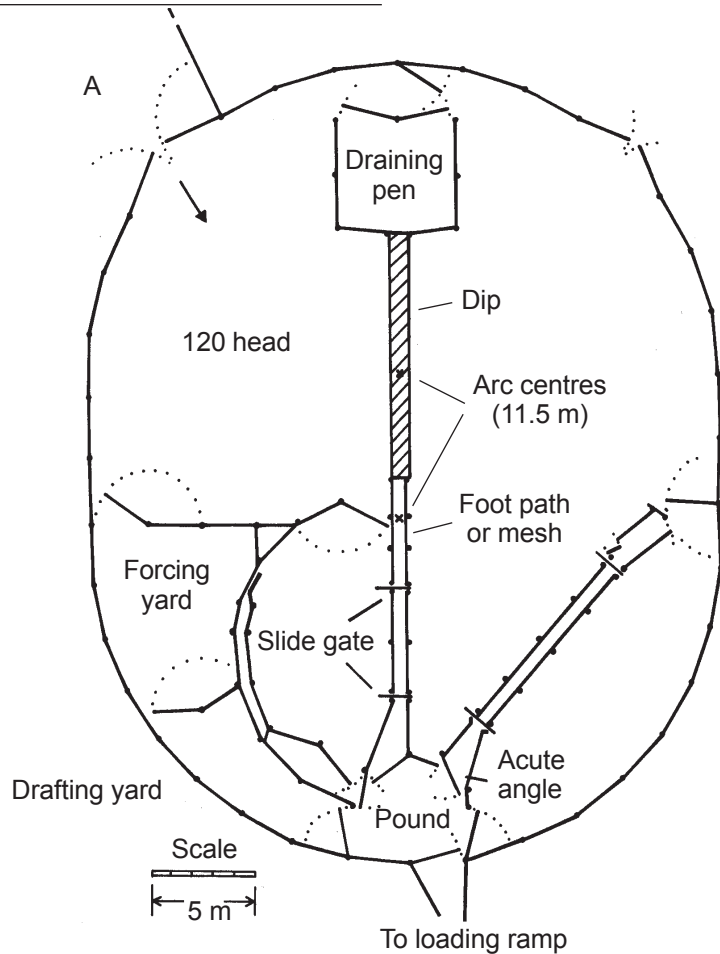

PLAN 10

This yard is a modification of the 'Yin-Yang' design. Cattle flow well in this teardrop-shape receiving yard. The plan provides a good receival-to-perimeter ratio but has insufficient post working area unless yard 'A' is expanded. One person can work this yard. Suitable for pound and race drafting. The narrow lane (3.7 m) is not suited to in-yard drafting of excitable cattle. The narrow lane is suitable for working cattle from a catwalk on the inside curve on the outside of the lane. A very large pound (6.6 m diameter). Perimeter radius 15 m; inside race radius 5.7 m.

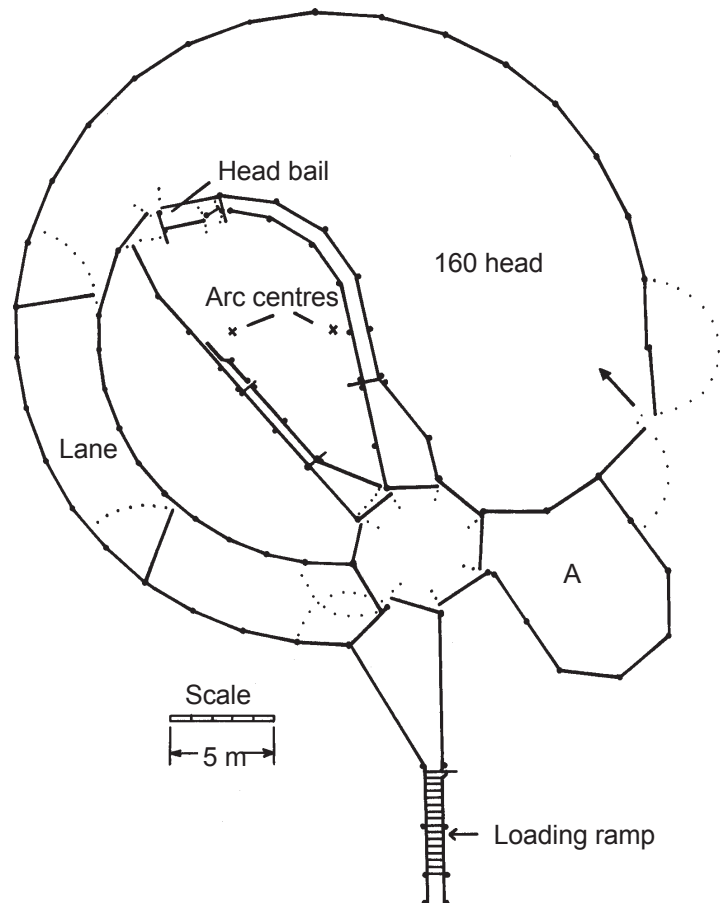

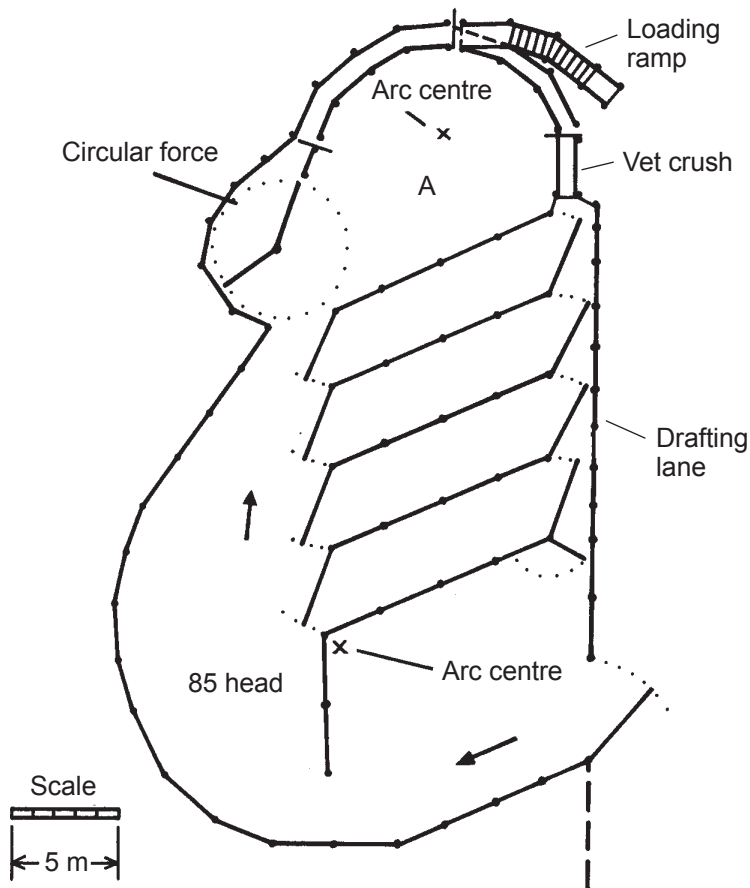

PLAN 11

This handling facility was planned by W. Vowles of Bendigo. It illustrates a circular forcing pen and laneway drafting system. The plan enables one-person operation but would be slow drafting unless remote control was used to operate the drafting laneway gates. Cattle work well in the circular forcing pen and curved race. Many cattlemen would not like excitable cattle being held in yard 'A' while they are working cattle in the race. Also if the ramp were straightened it would allow for easier side loading.

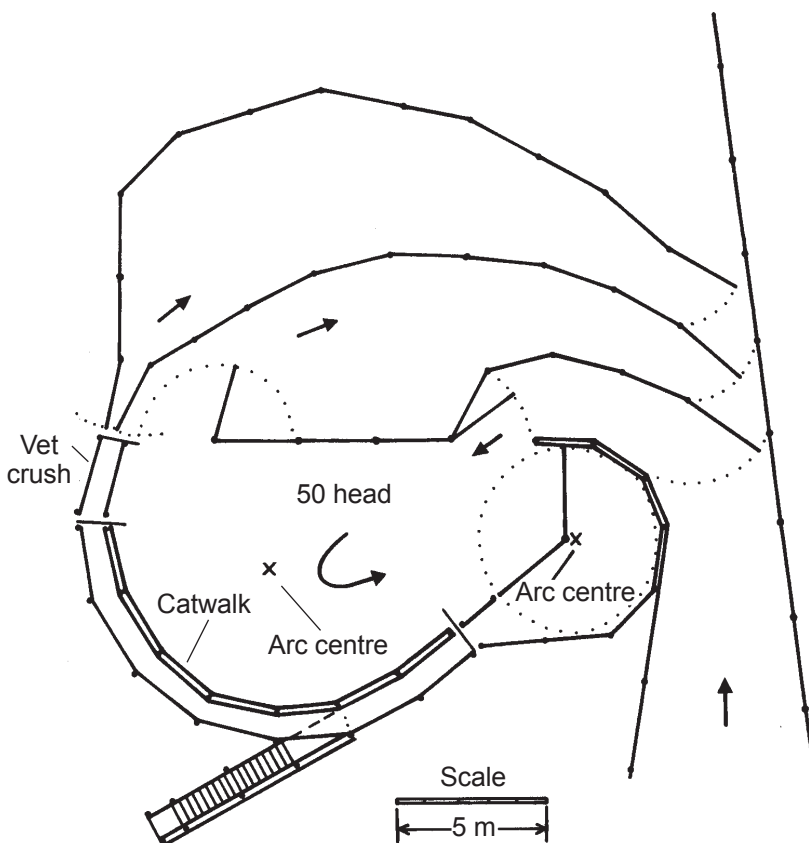

PLAN 12

This handling facility was planned by W. Vowles of Bendigo and is used successfully at several sites in Victoria and other states. The facility is attached to larger holding areas for increased capacity. As in plan 11, many cattlemen would not like excitable cattle in the yard near the crush and race while they are working there. They would prefer to have this a cattle-free area.

PLAN 13

This plan offers a pound and race drafting alternative. It also utilises many features based on cattle behaviour principles. The capacity can be expanded by increasing the size of yards 'A' and 'B'.

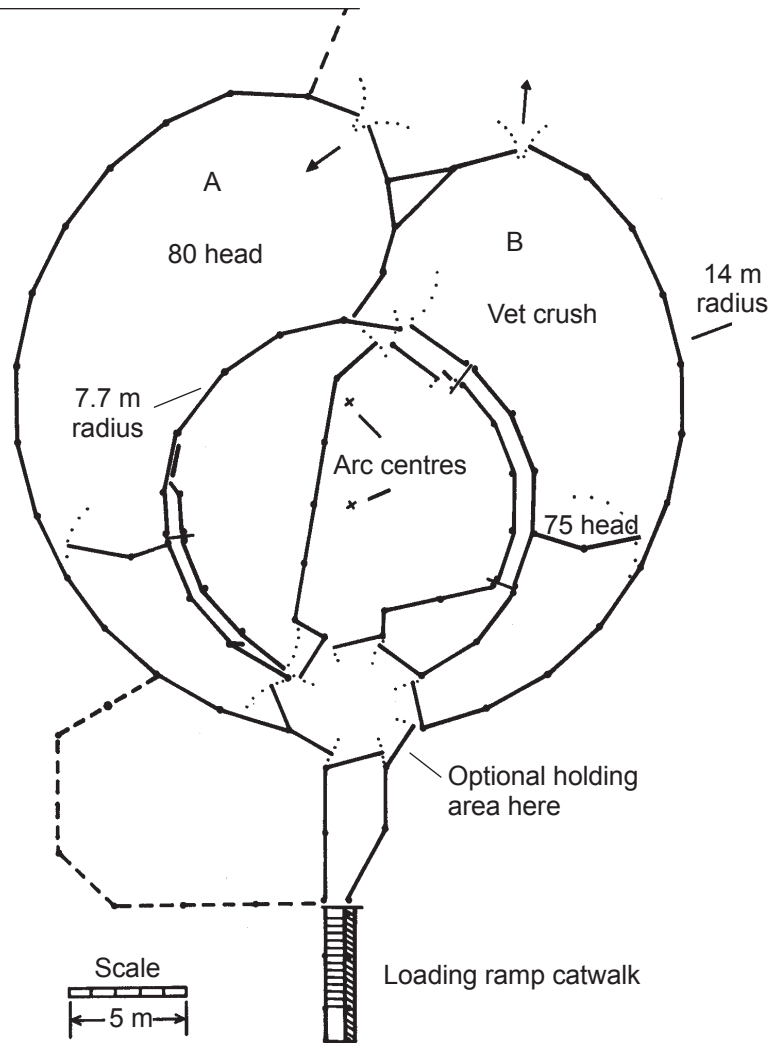

PLAN 14

This plan is adapted from Boral Cyclone yard plan CY8. Yard radius is 12 m. The idea of a pound by-pass to the main race is useful when little drafting is required or the race drafting facility is being used.

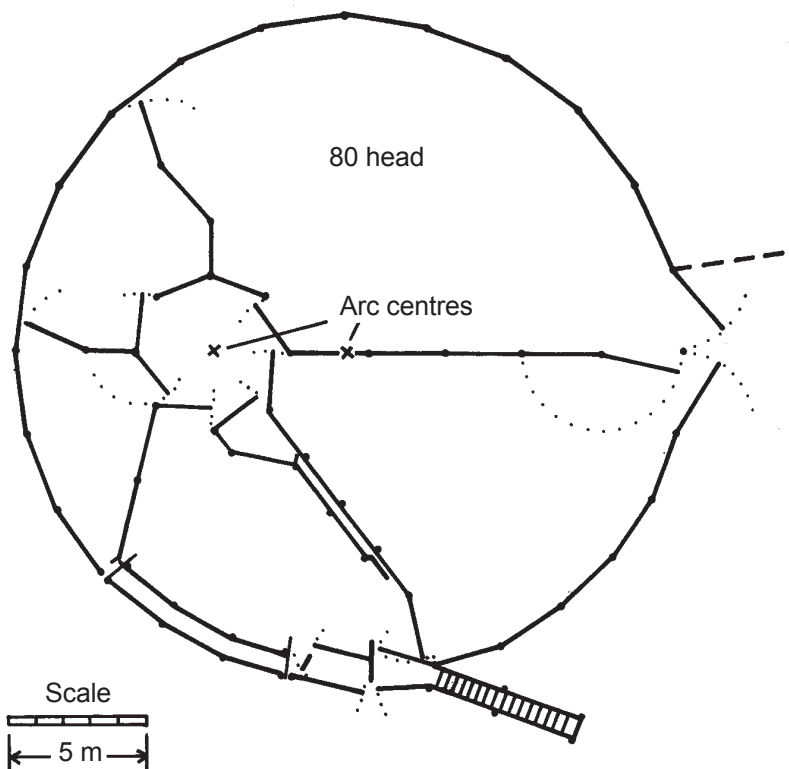

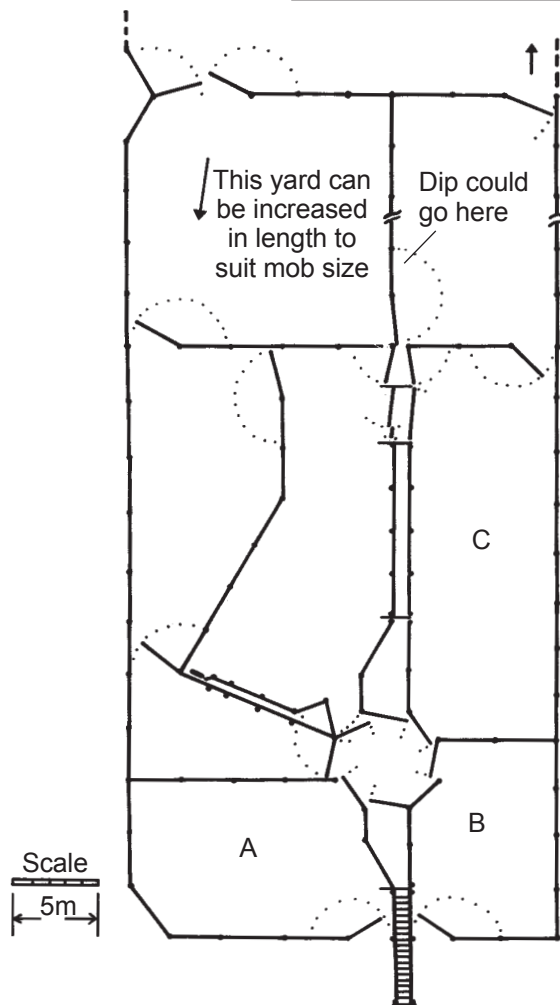

PLAN 15

This is a popular and proven yard design used in southern Queensland. The nucleus of the yard is suitable for handling small or very large mobs. The basic design was originally published by M. Weller in the *Queensland Agricultural Journal* (1968). This plan caters for four-way pound drafting or three-way race drafting. The design caters for easy expansion from the nucleus. Yards 'B' and 'C' are optional.

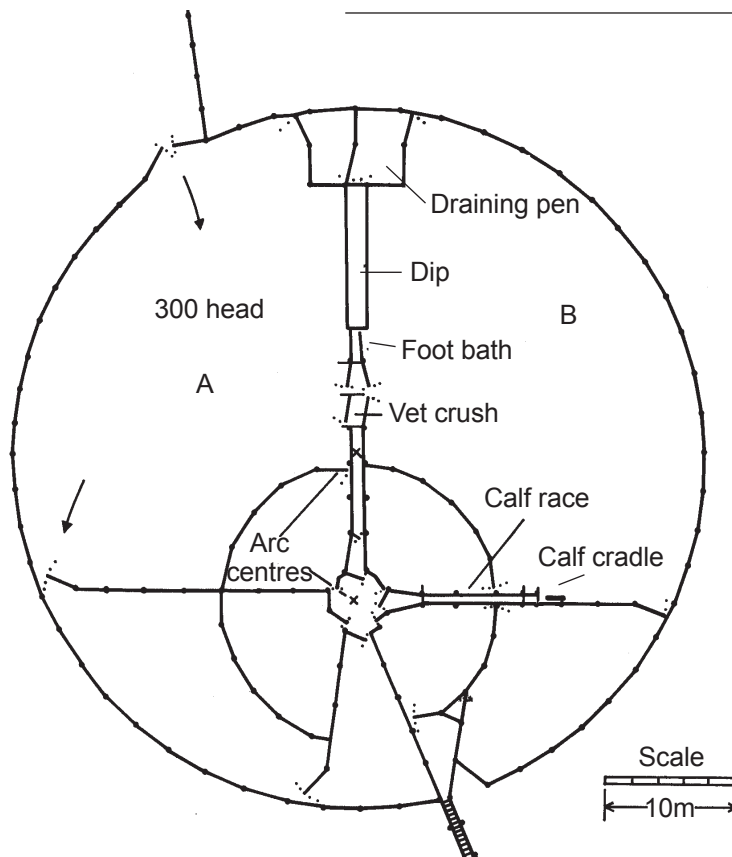

PLAN 16

This is a slightly modified version of a plan by J.J. Daly formerly of the Department of Primary Industries and Fisheries, Queensland. The circular perimeter gives a good perimeter to area ratio. The double draining pen should be modified to allow release from both pens to either yard 'A' or 'B'. Yard 'B' is excessively large when retrieving calves accidentally missed in the calf cradle.

PLAN 17

This yard is a slightly modified version of a yard built at 'Murilla', Tara. Cattle work extremely well in this yard. Yard 'B' could be made wider and an additional drafting pen could be constructed at 'A'. The gate at the rear of the drafting yard 'B' is handy for releasing calves when drafting cows from calves. One operator is able to work cattle in this yard.

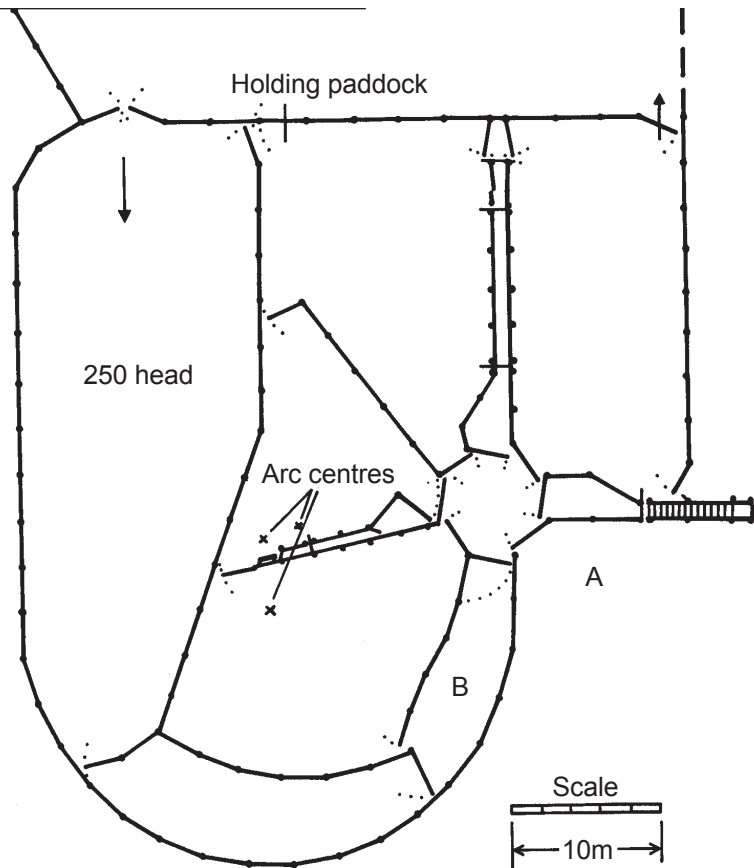

PLAN 18

This bugle yard was designed by M. Burns formerly of the Queensland Department of Primary Industries and Fisheries. Cattle work well around the curve and into the race. The rectangular pound or short drafting lane is suited to two-person operation. The race on the outside of the yard reduces possible race drafting alternatives. Yard capacity is increased by adjusting the size of the receiving yard or holding paddock.

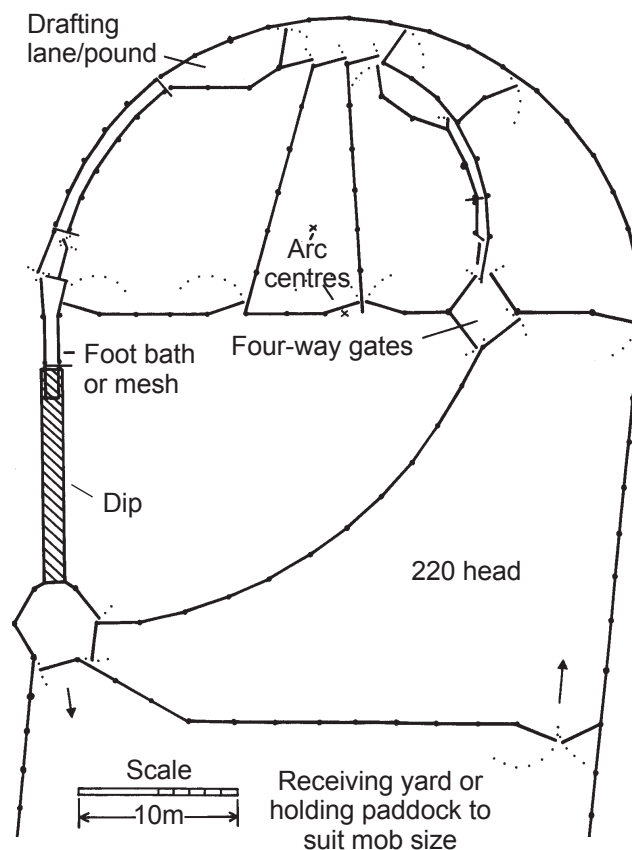

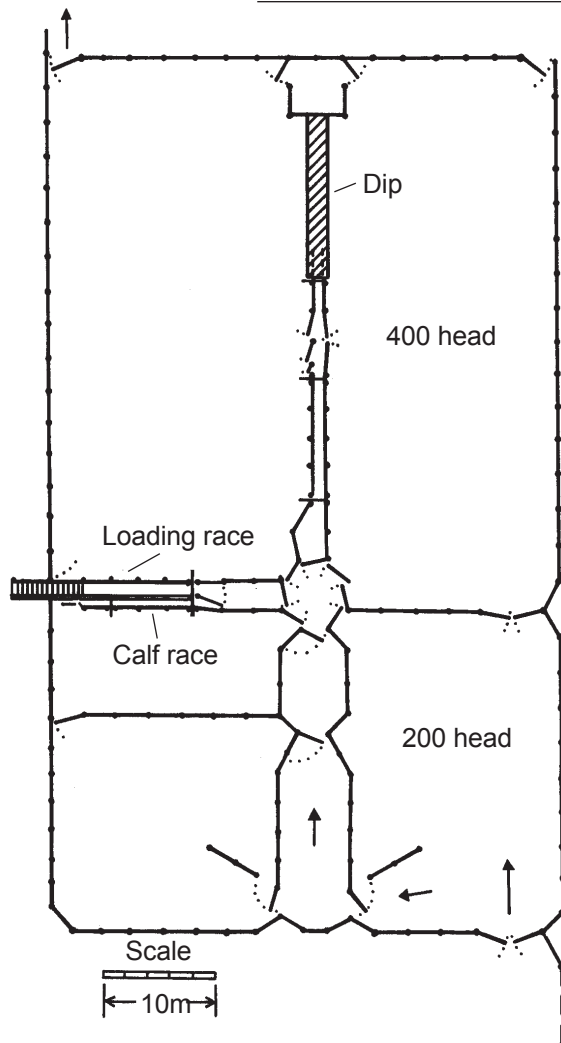

PLAN 19

The basic layout of this yard is taken from the 'Coorada' yards at Taroom. It is a system that has been successfully used for handling large numbers of cattle. Stock leave the yard complex from the end opposite to which they entered. This approach educates regularly handled cattle to move through the yard complex.

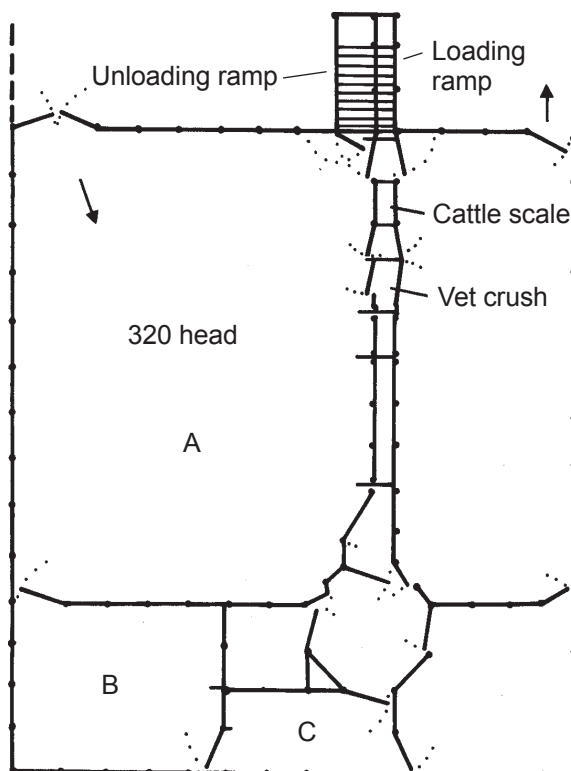

PLAN 20

This yard was published in *Cattle* magazine in 1974. Moving cattle from the wide receiving yard 'A' to the forcing yard 'B' would be difficult without sufficient stockmen. Yard 'A' needs a swing fence leading to yard 'B' or to be split into two yards. The wider unloading ramp is a good idea but loading could be slow through the long race set-up.

PLAN 21

This plan is by M. Burns, formerly of the Department of Primary Industries and Fisheries, Queensland. The double draining system enables release from either pen to yards 'A' or 'B'. The V-section in the receiving yard 'B' greatly assist with yarding operations. The right angle corners in the pound can be eliminated by moving the loading ramp forcing 'C' pen further out from the yard and tapering the pound to meet it. Nearside operators have to cross over the race to yard more stock with this layout.

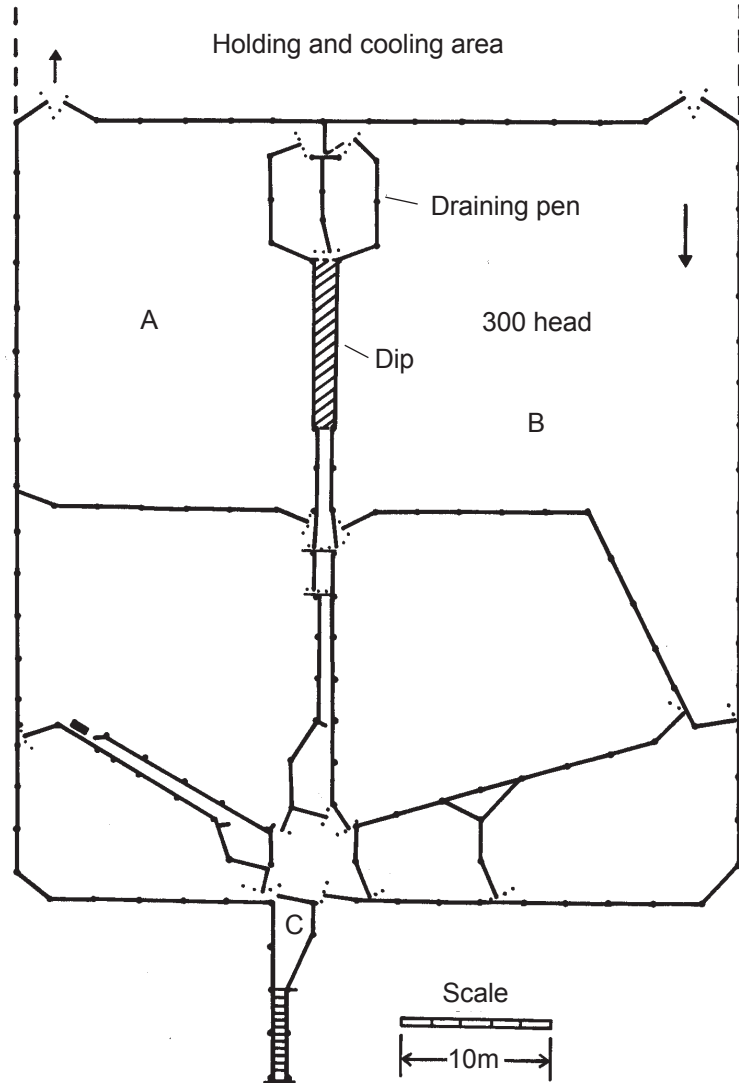

Glossary

belly rail a running rail at beast stomach height that prevents a beast being bruised on posts; or a rail to increase the visual barrier effect of the fence.

blank fence a fence that provides a complete visual barrier to stock. Stock cannot see through it.

branding cradle a device in which calves are held for branding, castration, vaccinations, dehorning and ear marking. Also called a branding frame.

britchen a chain, rail or half gate that holds the animal forward in the race or crush and prevents the operator being kicked by the animal or the animal moving backwards onto the operator.

cap or cap rail a stay between the top of two posts.

catwalk a raised walkway to enable the operator to work over the top of a race or loading ramp.

cladded blank fence or panel.

close working, close handling handling cattle in close proximity such as in forcing yards, drafting yards, pounds and forcing pens.

cooling yard a yard to hold cattle to let them settle down and rest before working through the yard or moving them back to pasture.

cradle see branding cradle.

crush in this book crush means a veterinary crush such as the head bail area at the end of the race.

dip an inground vat used for controlling cattle ticks and other external parasites.

dip wash, dip fluid the chemical liquid contained in the dip.

drafting sorting.

drafting yard a yard in which sorting is conducted.

drafting pen a yard into which cattle are sorted.

draw or draw in when cattle are encouraged to naturally move into a yard and then to the end of the yard opposite the entrance gate.

excitable fractious or wild cattle.

flapper a length of cane with a short strap of leather or canvas attached used to encourage the movement of cattle in response to sound.

forcing encouraging or pressuring cattle to move into a small yard, race or loading ramp.

forcing yard a yard used for forcing cattle into the drafting yard.

forcing pen the lead-in pen to the race or loading ramp.

fractious temperamental, uncooperative or wild (feral) cattle.

go down fall down or lie down.

gudgeon the portion of a hinge which fits into, and turns within, a pin or hook.

head bail a head-restraint device where animals are caught by the head.

holding yard a yard for holding cattle prior to the forcing yard or after they have been sorted.

loading ramp a structure for cattle to walk onto road transport vehicles.

manway a small gate or opening for the operator to move in and out of a yard. Not to be used by cattle.

near side the left-hand side of a beast.

nucleus yards those close-working yards necessary for basic handling of stock.

operator stockman.

offcuts the outside sawn-off section of milled logs.

off side the right-hand side of a beast.

panel the section between two consecutive posts in a fence.

pound a small yard with several gates leading to drafting pens.

race a single-file lane. Some cattlemen call a race a crush. This definition is not used in this book.

receiving yard the yard into which cattle first enter the yard complex. Can also serve as a cooling yard.

scruff to manually restrain a calf with or without the assistance of ropes but without the assistance of a cradle.

spray race a shower dip in which cattle are sprayed with chemical for cattle tick control. Not approved for interstate movement into clean country.

swing the arc which is made by an opening gate.

tails unfinished cattle.

tick cattle tick (*Boophilus microplus*).

tops finished cattle, best quality.

veterinary crush individual animal restraint facility (shown in figures 54 to 59).

visual barrier see blank fence.

Further reading and references

Animal Production Committee, 1985, National Workshop 'Cattle Handling Facilities and Procedures', Corowa, February 1985.

Biggers, J. (1977), Cattle Squeeze Crush, *Queensland Agricultural Journal* 103 (5), 392-400.

Burns, M. A. (1970), Planning Beef Cattle Yards, *Queensland Agricultural Journal* 96 (2),84-91.

Clarke, M. R. (1997), *Beef Cattle Production on the Darling Downs*, Department of Primary Industries, Queensland.

Department of Primary Industries, Queensland (1996), *Cow/Calf Separator* (handbook, video and plans) Q196024.

Daly, J. J. (1970), Circular Cattle Yards, *Queensland Agricultural Journal* 96 (5), 290-95.

DPI&F Notes: in *PrimeNotes CD-ROM*:

- Cattle Stock Gate Design for Trucks
- Cattle Transport (loading ramps)
- Cattle Transport

Available on CD and at www.dpi.qld.gov.au/dpinotes.

Grandin, Temple (1983), Livestock Handling from Farm to slaughter, *International Journal for the Study of Animal Problems*, Australian Government Publishing Service, Canberra.

Hall, W. J A. (1975), *Artificial Insemination in the Queensland Beef Cattle Industry*, Department of Primary Industries, Queensland.

Horcicka, J. (1983), Beef Cattle Yards, Tasmanian Department of Agriculture. Farmnote No.162.

Kearnan, J.F., McEwan, T., Reed, T.J. (1982), Dip Construction and Management, *Queensland Agricultural Journal* 108 (1), 25-47.

Mayer, B. G. (1969), Yards for Beef Cattle, *Queensland Agricultural Journal*, March 1969.

Paton, Tony, Cattle Working Pound, Information Sheet from the Department of Agriculture, New South Wales.

Pollard, D., Cavaye, J., Wythes, J. (1992), *Managing Small Herds of Beef Cattle*, Department of Primary Industries, Queensland.

Standing Committee on Agriculture (1991), Farm Cattle Handling, Report No.35.

Standing Committee on Agriculture (1992), Animal Health Committee: Australian Model Code of Practice for the Welfare of Animals: Cattle.

Sullivan, J. J., Alderdice, T. A. (1956), Crush and Walk-Through Bail Unit, *Queensland Agricultural Journal*, April 1956.

Waters, K. S. (1982), A Handy Squeeze Crush to Restrain Cattle, *Queensland Agricultural Journal*, July-August 1982.

Watts, Peter, Tucker, Robyn (1994), *Designing Better Feedlots*, Department of Primary Industries, Queensland.

Weller, M. C. (1968), Yards to Handle a Smaller Beef Herd, *Queensland Agricultural Journal* 94 (11), 678-80.

Wilton, R. J. (1987), Beef Cattle Yards for Less Than 100 Head, *AgFacts*, Department of Agriculture, New South Wales.

Legislative Acts and Regulations

Animal Care and Protection Act 2001

Workplace Health and Safety Act 1995

Workplace Health and Safety Regulations 1997

Workplace Health and Safety (Miscellaneous) Regulations 1995

Timber Utilisation and Marketing Act 1987

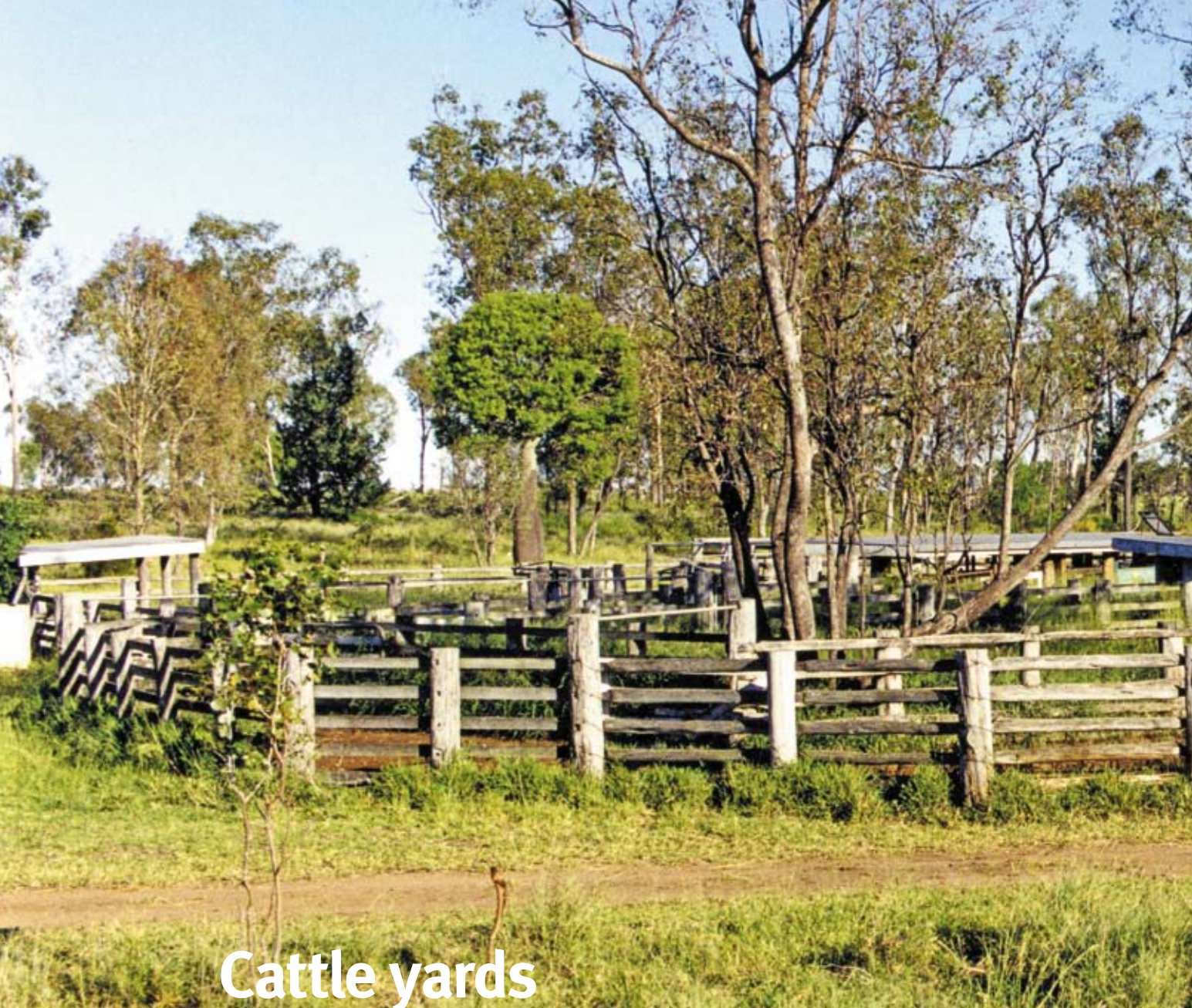

Cattle yards

is a how-to-do-it guide to locating, planning and building yards for cattle. It covers every aspect of building yards, including more than 80 diagrams to explain construction and 21 plans of cattle yards.

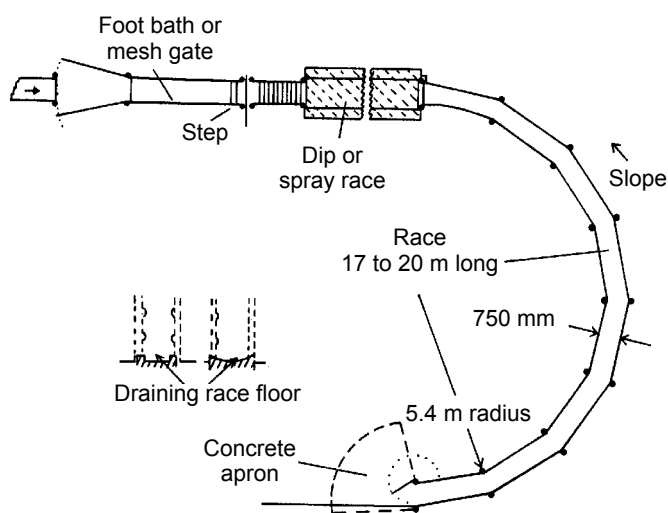

ISBN 0-7242-2259-6



9 780724 222599

0016C